

AC8710 INTELLIGENT 1.2 GHZ OPTICAL NODE



The AC8710 is an intelligent dual active output node for deep fibre solutions. It is based on fixed receiver but modular return path transmitter. Output amplifier stages use high performance GaN hybrids, which makes the usable output level range especially wide.

AC8710 has a USB connector for local configuration with a Windows PC/tablet or Android smartphone/tablet and supports wireless connectivity with AC6901 Bluetooth adapter. It has a slot for transponder module, which allows full remote monitoring and control of all node parameters. The transponder unit measures the forward and return path signal levels and enables the automatic forward and return path alignment function.

Node's dual power supplies are monitored by the transponder and increase the reliability of the node. Fully user configurable automatic level control (ALC) keeps output levels constant and automatic ingress blocking reacts to unwanted return path signals.

Features

- 1.2 GHz GaN HEMT technology
- 204 MHz return path
- Improved power handling capacity in housing
- Automatic alignment of both forward and return path
- Efficient surge and ESD protection
- Redundant power supply
- Electrical level and slope controls
- With AC6992/AC6983 transponder plug-in:
 - CATVisor / HMS (AC6992) or DOCSIS (AC6983) remote connection
 - ALC with fully user programmable pilots
 - Forward path spectrum analyser
 - Return path signal quality monitoring with automatic ingress control
 - True plug-and-play with single pushbutton alignment
 - Return path pilot generator (AC6992)

Technical specifications

Parameter	Specification	
Forward path		
Light wavelength	1290...1610 nm	
Optical input power range	-8...0 dBm	
Frequency range	85...1218 MHz	
Return loss	18 dB	1)
Gain limited output level	2 x 119 dBμV	2)
Input gain control	0...-26 dB	3)
Interstage gain control	0...-15 dB	4)
Slope control	0...20 dB	5)
Flatness	±0.5 dB	6)
Group delay	2 ns	7)
Test point	-20 dB	8)
Transponder connection	-19 dB	9)
Noise current density	5.0 pA/√Hz	10)
U _{max} (138 QAM channels) @1.2 GHz	112.5 dBμV	11)
U _{max} (138 QAM channels) @1.2 GHz (power save)	110.5 dBμV	
Max. TCP	70.0 dBmV	
MER	See curve	12)
CINR	See curve	12)
Return path		
Frequency range	5... 204 MHz	
Return loss	18 dB	13)
Flatness	±0.5 dB	13)
Ingress switching	0 / -6 / < -45 dB	
Input level	57.0 dBμV	14)
Maximum input level (TCP)	27 dBmV	15)
CINR	See curves	16)
OMI adjustment	0...-20 dB	
OMI test point	-5 dB	17)
Transponder connection	-37 dB	18)
General		
Power consumption	44 W	19)
Power save mode	- 6 W	
Current need	see note	19)20)
Supply voltage	27...65 VAC (sine or square wave) 45...90 VAC (square wave) 230 VAC	
Maximum current feed through	12.0 A / port	
Hum modulation	70 dB	21)
Optical connectors	SC/APC, E-2000	
Output connectors	PG11	
Test point connectors	F female	
Dimensions	245 x 255 x 155 mm	h x w x d
Weight	5.0 kg	
Operating temperature	-40...+55 °C	
Class of enclosure	IP 54	
EMC	IEC 60728-2	
ESD	4 kV	22)
Surge	6 kV (EN 60728-3)	

Notes

- 1) The limiting curve is defined at 40 MHz -1.5 dB / octave. Return loss is always > 13 dB.
- 2) This is the gain limited output level when OMI is 4.0 %. The level is available with the optical input power of -8 dBm . The used wavelength is 1310 nm.
- 3) Step size is 0.5 dB. This control is used by OLC.
- 4) Step size is 0.2 dB. This control is used by ALC. Flatness spec is guaranteed when attenuation is less than 13 dB.
- 5) Step size is 0.5 dB. Slope is defined between 85...1218 MHz. Flatness specification is not valid for >15 dB slope values and accuracy may be worse.
- 6) Typical value in room temperature with closed lid and installed US transmitter. Guaranteed value is ±0.85 dB.
- 7) Typical value for 4.43 MHz band. Measured at channel S2 when 65 or 85 MHz return path is in use. At higher frequencies the performance is better.
- 8) TP has a tolerance of ±0.75 dB between 85...862 MHz and ±1.0 dB between 862...1218 MHz.
- 9) Level difference between transponder connection and output 1. Tolerance ±0.5 dB.
- 10) Typical C/N curves.

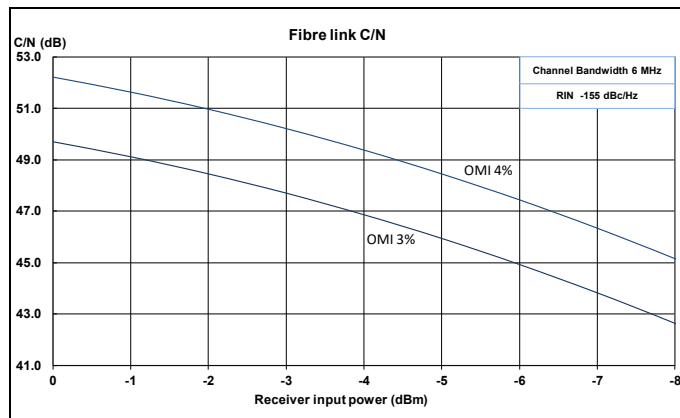

- 11) Typical value according to IEC60728-3. Full digital loading (J.83 annex A) up to 1218 MHz in use. Channels have 13 dB cable equivalent slope between 85...1218 MHz.

12) MER and CINR

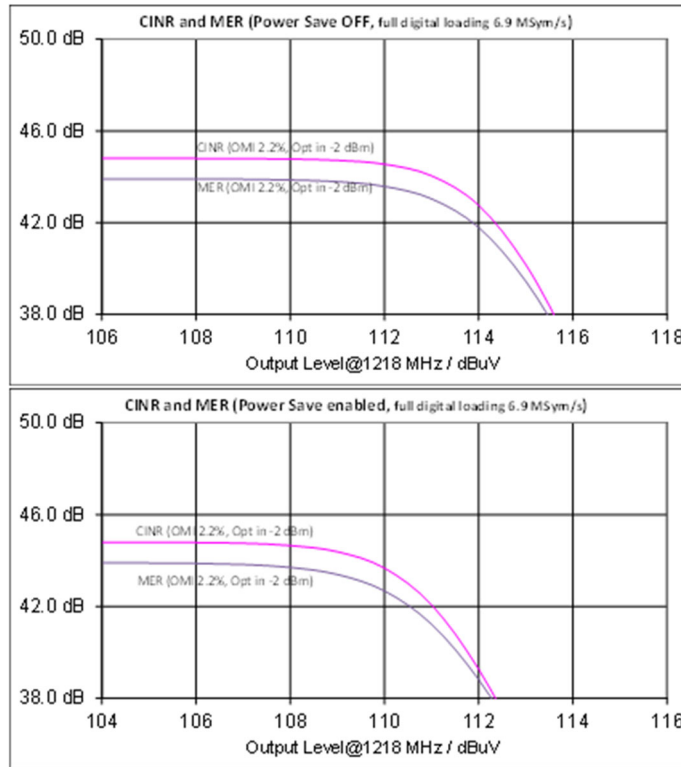

13) Valid after 8 MHz.

14) Nominal input level for 4.0 % OMI (ch). Defined at the output connector of the node. Maximum recommended OMI (tot.) is 25 %.

15) This is a limitation of a mother board.

16)

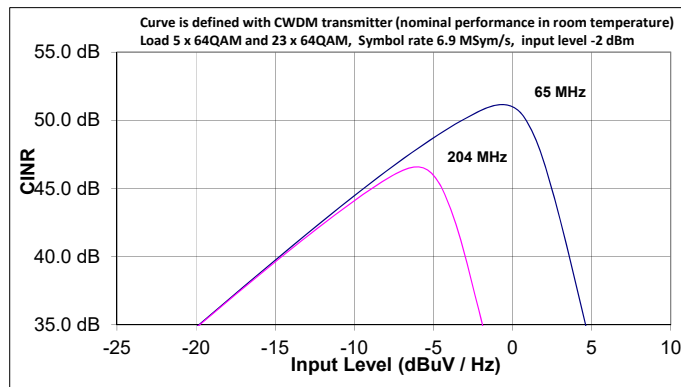

17) -5 dB is valid with 0 dB ingress switch and 0 dB input attenuator. The nominal value at this TP is 52 dBμV when OMI is set to 4 %. Tested at 20 MHz.

18) This is the level difference between return path input and transponder transmit pin when return path attenuation is 0 dB. This value increases linearly with increasing return path attenuation.

19) Power consumption is given with transponder (AC6992 and with optical CWDM transmitter. Single PSU was used).

20)

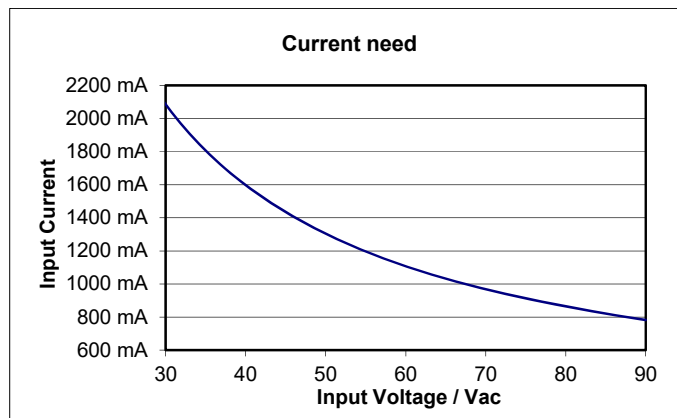

- 21) 70 dB hum value is valid at any frequency from 10 to 1218 MHz, when the remote current is less than 10 A/ port. Hum modulation is 60 dB, if 12.0 A is fed. 16.0 A is the maximum current, which can be locally injected into both ports together.
- 22) EN61000-4-2, contact discharge to enclosure and RF-ports.

Compatibility

All accessories that are used with this product should use the newest generation available. By using only up-to-date accessories a proper operation can be ensured.

Monitoring functions

- Status LED for alarm indication
- Return path ingress switches on / attenuated / off control
- Remote AC voltage measurement with alarms
- Local +12 V and +24 V voltage measurements with alarms
- Internal temperature measurement with alarms
- Full electrical control of all forward and return path alignments
- OMI based forward path automatic alignment
- OMI based return path automatic alignment
- Uptime, total uptime and reset counters for power outage statistics
- User notes can be stored into amplifier memory
- Fully user configurable alarm limits, severities, enabling and delays
- Alarm log stored into non-volatile memory for easy troubleshooting
- Node configuration and accessory information stored in amplifier memory
- Local configuration via USB using PC, Windows tablet or Android smartphone or tablet
- Fast local software update via USB also without power supply
- Optical receiver input power measurement with alarms
- Optical transmitter laser bias current measurement with alarms
- Optical transmitter pilot generator enabling and frequency control

Additional features available with AC6992 / AC6983 transponder:

- Remote access to all AC8710 settings and monitored parameters
- ALSC and modem LEDs for alarm indication
- CATVisor and HMS compatible remote connection (AC6992)
- DOCSIS compatible remote connection (AC6983)
- Interstage gain control by ALC mode with saturation alarm
- ALC pilot frequencies, types and decision levels are user programmable
- Automatic reserve pilot switching
- Pilot based forward path automatic alignment
- Full forward and return path automatic alignment with a single button
- Lid status monitoring with alarm
- Service terminal connection monitoring with alarm
- Configuration change monitoring with alarm
- Spectrum analyser for forward path level measurement with alarm
- Ingress analyser for return path level measurement with alarms
- Automatic ingress switch activation and deactivation independently for both inputs based on detected ingress with alarms and user configurable delays
- Modem receive and transmit signal level monitoring with alarms (AC6992)
- Remote software update also to multiple units simultaneously, without affecting operation
- Return path pilot generator with 4 user programmable pilot frequencies and levels (AC6992)

Block diagram

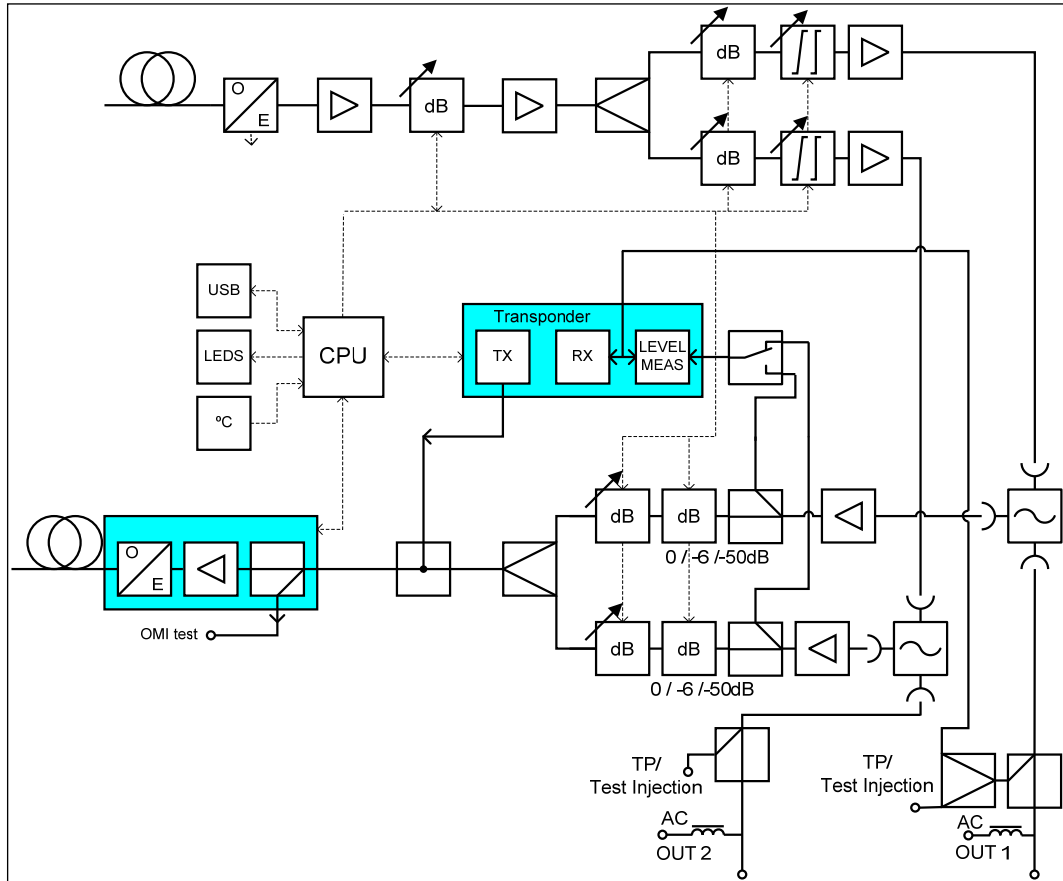

Ordering information

AC8710 configuration map

	1-			2-			3-	4-	5-			6-	7-	8-			9-
	1	2	3	1	2	3	1	1	1	3	1	1	1	1	2	3	1
AC8710																	

1-1 Platform type
B Standard 1.2 GHz (2nd gen.)
1-2 Power supply
A Single PSU, 65 VAC (1x AC6310)
B Double PSUs, 65 VAC (2 x AC6310)
C Local powering, euro plug (230 VAC)
D Customer specific option
E Single PSU, 90 VAC
F Double PSUs, 90 VAC
1-3 Fiber optic
A Standard fibre organiser

2-1 Fibre feed-through adapter
E 5/8 Adapter (KDC316)
G 1-4 fibres (KDO900)
X None
2-2 Output 2 connection
A PG11
B 5/8"
C IEC
D 3.5/12
E F
K Customer specific option
2-3 Output 1 connection (first from right)
A PG11
B 5/8"
C IEC
D 3.5/12
E F
K Customer specific option

3-1 Optical connector for receiver
A SC/APC, 9 deg.
C E-2000
D SC/APC, 8 deg.

4-1 Diplexer filter
D 65/85 MHz (2 x CXF065)
G 65/85 MHz (2 x CXF065 19)
H 85/105 MHz (2 x CXF085 S)
I 85/105 MHz (2 x CXF085 19)
J 204/258 MHz (2 x CXF204)
K 204/258 MHz (2 x CXF204 19)
L 204/258 MHz (2 x CXF204 10)
X None

5-1 Return path transmitter
40 +1dBm FP 1310 nm (AC67B40)
41 +3 dBm CWDM 1430 nm (AC67B41)
42 +6 dBm CWDM 1430 nm (AC67B42)
43 +3 dBm CWDM 1450 nm (AC67B43)
44 +6 dBm CWDM 1450 nm (AC67B44)
45 +3 dBm DFB 1310 nm (AC67B45)
46 +6 dBm DFB 1310 nm (AC67B46)
47 +3 dBm CWDM 1470 nm (AC67B47)
48 +6 dBm CWDM 1470 nm (AC67B48)
49 +3 dBm CWDM 1490 nm (AC67B49)
50 +6 dBm CWDM 1490 nm (AC67B50)
51 +3 dBm CWDM 1510 nm (AC67B51)
52 +6 dBm CWDM 1510 nm (AC67B52)
53 +3 dBm CWDM 1530 nm (AC67B53)
54 +6 dBm CWDM 1530 nm (AC67B54)
55 +3 dBm CWDM 1550 nm (AC67B55)
56 +6 dBm CWDM 1550 nm (AC67B56)
57 +3 dBm CWDM 1570 nm (AC67B57)
58 +6 dBm CWDM 1570 nm (AC67B58)
59 +3 dBm CWDM 1590 nm (AC67B59)
60 +6 dBm CWDM 1590 nm (AC67B60)
61 +3 dBm CWDM 1610 nm (AC67B61)
62 +6 dBm CWDM 1610 nm (AC67B62)
XX None

5-3 Optical connector for transmitter
A SC/APC, 9 deg.
C E-2000
D SC/APC, 8 deg.
X None

6-1 Optical filter 1
F1 WDM with 8 deg. SC/APC connectors
F2 WDM with 9 deg. SC/APC connectors
XX None

7-1 Transponder module
E Transponder and ALS module (AC6992)
H DOCSIS transponder (AC6983)
X None

8-1 Transponder communication protocol
A CAT/Visor compatible
B HMS/SNMP compatible

8-2 Settings
X Factory default
A Customer specified

8-3 Product keys (software features)
X None
C Auto alignment, spectrum and ingress analyser, pilot generator

9-1 Customer specific selections
B Customer specific option
X None

9-2 Accessories
A USB extension cable
X None