



# User Manual

## **AC8710 Intelligent optical node**

59300573, Rev. 005

**TELESTE**

---

**Contents**

<b>Introduction.....</b>	<b>3</b>
AC8710 generations .....	4
<b>Installation.....</b>	<b>5</b>
Housing .....	5
Interfaces.....	6
Transponder .....	7
Fibre connections .....	8
Optical receiver .....	9
Optical return transmitters .....	9
Powering.....	10
Installing the PSU.....	12
Fibre installation.....	14
Fibre management .....	15
Front panel .....	16
<b>Features.....</b>	<b>17</b>
Diplex filter modules .....	17
Automatic alignment.....	17
Forward path.....	19
Return path.....	26
Remote communication.....	29
Establishing a connection.....	31
Alarms.....	32
Led usage.....	34
Product key activation of advanced features.....	35
Transferring AC8710 settings .....	35
Updating AC8710 software .....	37
Updating transponder software.....	37
SNMP MIBs.....	38
<b>Viewer pages .....</b>	<b>39</b>
Status viewer page .....	40
Forward path viewer page .....	45
Return path viewer page.....	49
Transponder viewer page (CATVisor).....	52
Transponder viewer page (HMS).....	55
Transponder viewer page (DOCSIS).....	57
Spectrum viewer page.....	58
Ingress viewer page.....	61
Properties viewer page.....	63
<b>Legal declarations .....</b>	<b>65</b>

---

## Introduction

The AC8710 is an intelligent dual active output node for deep fibre solutions. It is based on fixed receiver but modular return path transmitter.

Output amplifier stages use high-performance GaN hybrids, which makes the usable output level range especially wide. The platform and accessories of AC8710 are fully functional up to 1.2 GHz.

The platform has a slot for transponder module, which allows full remote monitoring and control of all node parameters. The transponder unit measures the forward and return path signal levels and enables the automatic forward and return path alignment function. Node's dual power supplies are monitored by the transponder and increase the reliability of the node.

Local configuration of AC8710 is done via its USB interface using a Windows PC or tablet equipped with CATVisor Commander software or an Android mobile device equipped with Teleste Commander software. Wireless Bluetooth connection can be established with AC6901 USB to Bluetooth adapter.

### AC6981, AC6983 and AC6992 transponder units

AC8710 node can be equipped with an optional plug-in transponder unit. The features with different transponder units are described in Table 1. See the transponder spec sheet for details.

AC8710 feature map vs transponders	None	AC698x	AC699x
Intelligent continuous adjustments	●	●	●
Local control through USB connection	●	●	●
CATVisor/HMS monitoring and control	-	-	●
DOCSIS remote monitoring and control	-	●	-
ALC with fully user programmable pilots	-	●	●
Automatic forward path OMI alignment	●	●	●
Automatic return path OMI alignment	●	●	●
Automatic forward path pilot alignment <sup>1)</sup>	-	●	●
Full single button automatic alignment <sup>1)</sup>	-	●	●
Forward path spectrum analyser <sup>1)</sup>	-	●	●
Return path ingress analyser with automatic ingress control <sup>1)</sup>	-	●	●
Return path pilot generator <sup>1)</sup>	-	-	●

1) These features need to be enabled with a Product Key.

Table 1. AC8710 feature map

## AC8710 generations

AC8710 has 2 generations with some differences in hardware and software:

1st generation AC8710:

- Manufactured ...Q4/2021
- Compatible with software versions 4.x.x

2nd generation AC8710:

- Manufactured Q3/2021...
- Slightly improved forward path output level and noise current density
- Compatible with software versions 6.x.x

AC8710 viewer shows generation information on the "Properties" viewer page.

The configuration code on the sticker on the side of AC8710 housing shows "A..." for 1st generation units and "B..." for 2nd generation units.

AC8710	1st gen	2nd gen
Manufactured	...Q4/2021	Q3/2021...
Configuration code on housing sticker	A...	B...
Gain limited output level (dB $\mu$ V)	118	119
Noise current density (pA/VHz)	6.0	5.0
Compatible software versions	4.x.x	6.x.x
SNMP sysOID text	ac8710	ac8710-2ndgen

*Table 2. AC8710 generations*

## Installation

### Housing

The AC8710 can be installed either into a street cabinet or to the outdoor environment. The fibre node should be installed vertically so that the external cable connectors and ventilation hole are underneath, securing the housing with three mounting brackets. When positioning the fibre node in its final location, make certain that it has adequate ventilation on all sides. In particular, it is necessary to provide at least 150 mm of room above the fibre node for air circulation. Figure 1 depicts the positions of mounting brackets as well as other installation dimensions.

AC8710 is equipped with an easily removable lid. The lid opens with the hinges to the left. The open cover can be removed by first opening the lid into a 90 degrees angle and then lifting it off the hinges.

Before closing the lid it should be checked that:

- nothing is trapped between the lid and the case
- all case gaskets are intact and in their correct positions
- lid seats evenly on the rubber gasket

Using a 4 mm Allen key, the lid retaining bolts are fastened in a diagonal sequence with a tightening torque of 3 Nm. The class of enclosure is IP54 when correctly installed and tightened.



**NOTICE:** IP54 type enclosure - This enclosure provides protection from airborne dust and light sprays or splashing water from all directions.

Node housing should be grounded using a copper conductor of at least 4 mm<sup>2</sup> cross-section area from proper earth to the housing ground lug. Proper grounding will improve protection from the effects of interference and thus increase the overall reliability of the system.

8616070

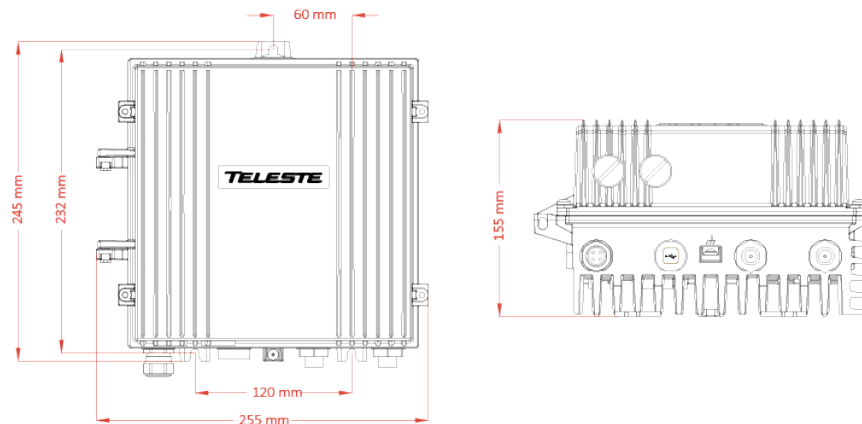
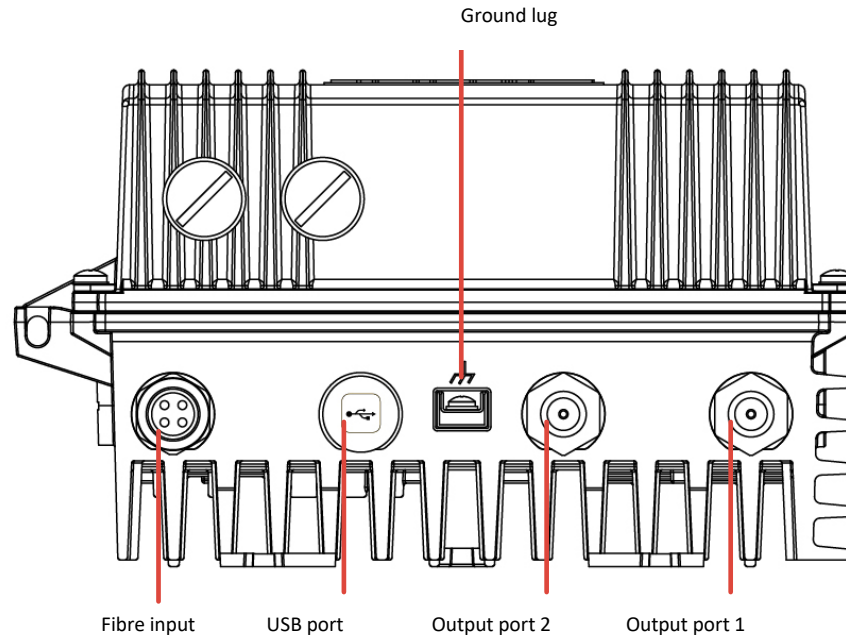

Figure 1. AC8710 housing dimensions – top and side view

**Interfaces**

8611054

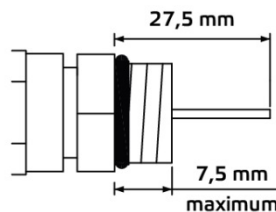

*Figure 2. Port locations*

The AC8710 node has three dedicated cable connection points: one input for fibre entry and two coaxial RF outputs. In addition, there is a port for the USB management interface.

All coaxial outputs have a standard PG11 thread and they accept any KDC type adapter or connector. A suitable length for the centre conductor pin is approximately 20 mm (Figure 3). Screw the KDC connector/adapter body into the port. Tighten the centre conductor seizure screw and torque to 0.7 Nm. Do not over-tighten.

8604025



*Figure 3. Centre conductor length*

## Transponder

8619025

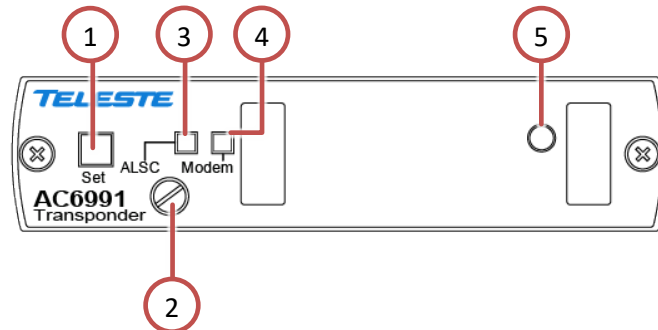

Figure 4. AC6991 DOCSIS transponder unit, 1) "Set" -button, 2) Fastening bolt, 3) Indicator for ALSC status, 4) Indicator for modem status, 5) Ambient light sensor

8619033

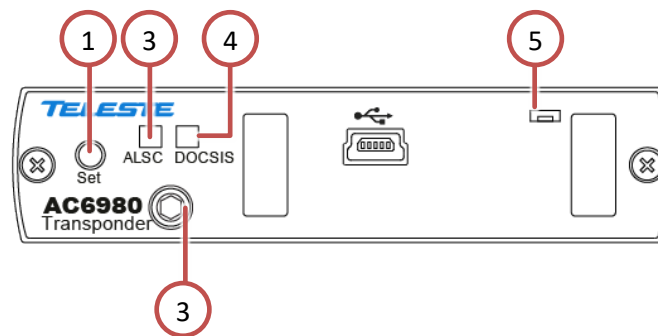

Figure 5. AC6980 transponder unit, 1) "Set" -button, 2) Fastening bolt 3) Indicator for ALSC status, 3) Indicator for DOCSIS status, 4) Remote management USB connector, 5) Ambient light sensor

To install a transponder unit, first locate the correct installation position. Snap off the segments of the shrouds break-away type slot cover and remove the slot cover. Insert the unit by pressing it gently into place. The unit will fit only in one orientation. Finally tightly fasten the mounting bolt with a tightening torque of 1.2 Nm to ensure proper grounding and cooling using a 3 mm Allen key. There is no need to switch off the supply voltage during module installation.

## Fibre connections

The node accepts up to four fibre cables. These fibres carry forward path and return path optical signals. When feeding the optical cable into the node a PG11 threaded feed-through adapter type KDO900 is available.

### KDO900 adapter and fibre fitting

Remove the outer ring of the cable gland, thread the installation fibre filaments with connectors through the outer ring (Figure 6 pos. 3), through the sealing insert (Figure 6 pos. 2) and finally through the cable gland (Figure 6 pos. 1).

Mount the cable gland on the housing. The fibre filament length inside the fibre organiser is adjusted to sufficient measurement before tightening the outer ring.

Use the synthetic locking pins (supplied) to seal up unused holes in the sealing insert.

8606022

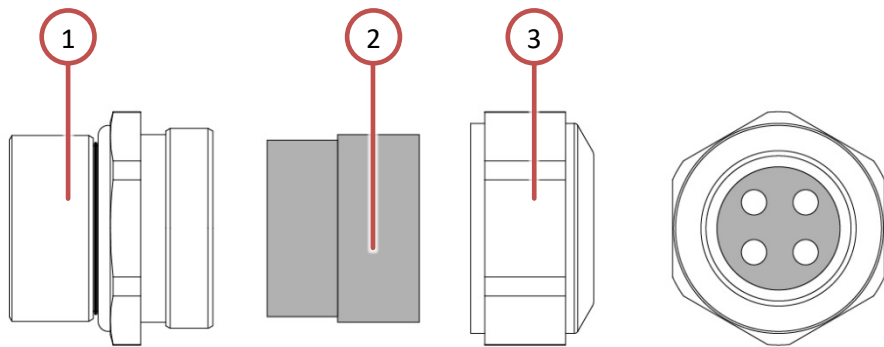

Figure 6. KDO900 adapter components

## Optical receiver

The optical receiver is integrated within the AC8710 and accepts both 1310 and 1550 nm wavelength optical inputs. The optical receiver provides both a led indicator and DC voltage test point for received optical power to quickly determine status of the unit.

## Optical return transmitters

There are a variety of options for transmitter modules available for the return path applications of ACcess platform (AC67 Tx). The return path transmitters are available either in 1310 nm or 1550 nm DFB versions. In addition, the platform can be equipped with CWDM transmitters. The CWDM lasers deploy eight wavelengths in range of 1470...1610 nm. The wavelength and optical output power are marked on the product label.

8611055

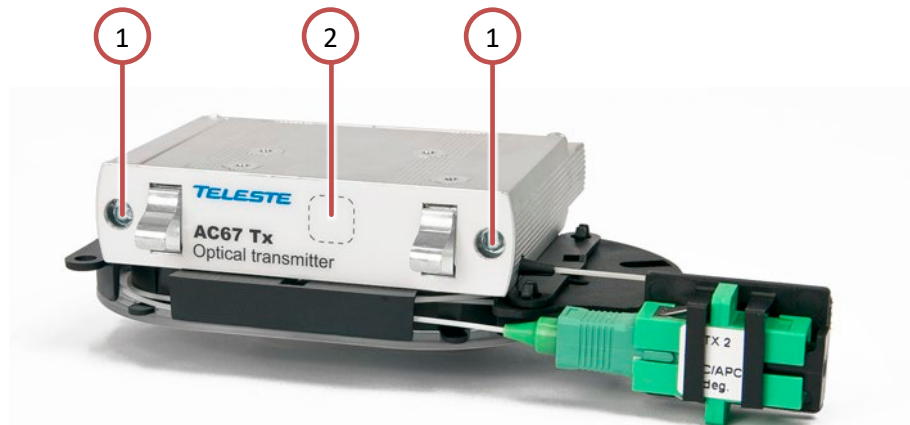

Figure 7. AC67B Optical transmitter with integrated fibre organiser,  
1) Fastening bolt, 2) Product label

To install AC67 Tx optical unit, first locate the correct installation position. Insert the unit by pressing it gently into place. The unit will fit only in one orientation. Finally, using a 3 mm Allen key, fasten the mounting bolts with a tightening torque of 1.2 Nm. There is no need to switch off the supply voltage during module installation.



**NOTE** that optical units shouldn't be installed or removed while the unit is powered via USB only.

## Powering



**WARNING:** To reduce the risk of electric shock, do not remove the shielding cover of the power supply unit if it is connected. All electrical installations must be carried out by authorized and competent technicians in accordance with the national or regional electrical regulations.

### Common precautions:

- The AC8710 node is intended for installation in restricted access locations (dedicated equipment rooms, equipment closet, or the like).
- Operate the device only on the specified supply voltage.
- The AC8710 must never be operated without its power supply unit shielding cover.
- The AC8710 has no separate power switch thus the power plug must be easily accessible.
- Disconnect the power cord by the connector only. Never pull on the cable portion of the power cord.
- Do not place or drop heavy or sharp-edged objects on the power cord.
- The power must be disconnected when installing or removing the AC8710.

### Additional safety requirements for Norway and Sweden:

- Equipment connected to the protective earthing of the building installation through the mains connection or through other equipment with a connection to protective earthing and to a cable distribution system using coaxial cable, may in some circumstances create a fire hazard. Connection to a cable distribution system must be provided through a device providing electrical isolation below a certain frequency range (galvanic isolator, see EN 60728-11).

The AC8710 can be powered by several PSU options. Every option has its advantages and limitations which are described briefly as follows.

#### 230 V AC:

The locally powered AC8710 node is connected to the mains voltage of 205...255 V AC via its own power cord. The power supply unit is double shielded and does not require separate grounding. However, ensure that the housing of the AC8710 is properly connected to the earth in order to meet safety requirements. Proper grounding will also improve protection from the effects of interference and thus increase the overall reliability of the system.

#### 27...65 V AC:

The AC6310 power supply unit accepts 27...65 V AC either via a coaxial cable by inserting a fuse to the corresponding fuse holder or directly at the external input. The external input is located on the power distribution board at the upper right corner of the node. External power can also be fed through the node into the network. The maximum feed-through current is 12 A per port. If power will be provided through a dedicated output port, the port must be equipped with a fuse (supplied).

#### 40...90 V AC:

The node can alternatively be delivered with a 45...90 VAC (square or quasi square) for remote supply. Power is supplied either via a coaxial cable by inserting a fuse to the corresponding fuse holder or directly at the external input. The external input is located on the power distribution board at the upper right corner of the node. External power can also be fed through the node into the network. The maximum feed-through current is 12 A per port. If power will be provided through a dedicated output port, the port must be equipped with a fuse (supplied). Note! This PSU option is not fully compliant with the EN 60728-11:2010 standard because powering voltage can exceed 65 V AC.

In general, only one power supply is needed in the node. However, the power supply unit can work alone or in dual-operation mode if a backup of the PSU is needed. In dual powering operation, the units are connected in parallel operating in a passive load-sharing mode. The output voltages can be separately monitored via user interface. Note! The 230 V PSU cannot be used in dual-operation mode.

#### Cable gland at external input

The cable gland assembly provides the necessary protection against the ingress of solid objects and moisture as well as providing cable retention.

8611063

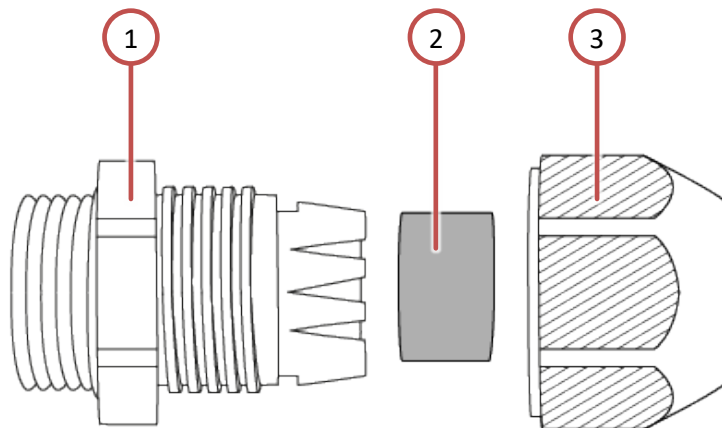

Figure 8. Cable gland components

Strip the cable sheath of the supply cord with a suitable length to suit the equipment and pass it through gland nut (3), seal (2) and plug body (1). Place appropriate conductors into plug pin housing assembly terminals and tighten screws to secure bared conductors and ensure good electrical contact. Screw the plug body tight onto the node housing to ensure that the IP rating is maintained. Position the end of the cable sheath in line with the plug body and tighten the gland nut.

## Installing the PSU

To gain access to PSU retaining screws, first remove the protective aluminum shroud. The shroud is attached to the lid, to shield the electronics from electromagnetic interference. Install the PSU board with the four M3x8 mm torx screws (Figure 9 pos. A). Use the silicon elastomers (Figure 9 pos. C) between the unit and the heatsink brackets. Make sure to use the fixing springs in the locations marked with B (Figure 9).

ac8k\_power\_b

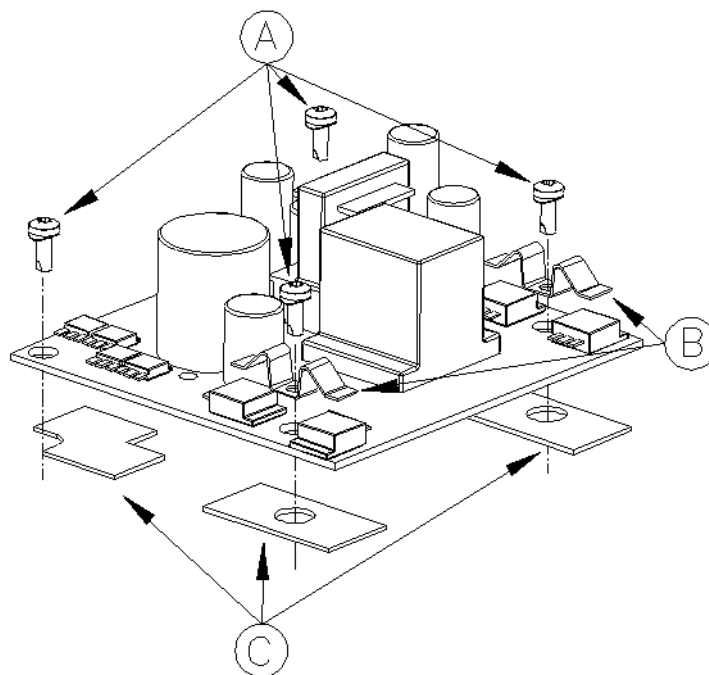

Figure 9. AC6310 mounting screws (A), fixing springs (B), and silicon elastomers (C)

Primary and secondary power supplies are physically identical. Their functional differences are controlled by a jumper. See Figure 10 for locations of the jumper pins. The jumper must be positioned prior to installation. The primary power supply unit must be installed into the first place (closest to the hinges). Locate the 10-pin connectors and attach the supplied ribbon cable.

After PSU installation carefully refit the shroud in the reverse order of removal. Ensure that all RFI gaskets are in place before the shroud is refitted.

Before connecting the power make sure that

- both power supplies are installed in correct positions
- jumpers is set correctly (Figure 10)

Connect the power source. The led on the PSU circuit board indicates that the unit is powered up and that the DC power supply voltage is present.

8609091

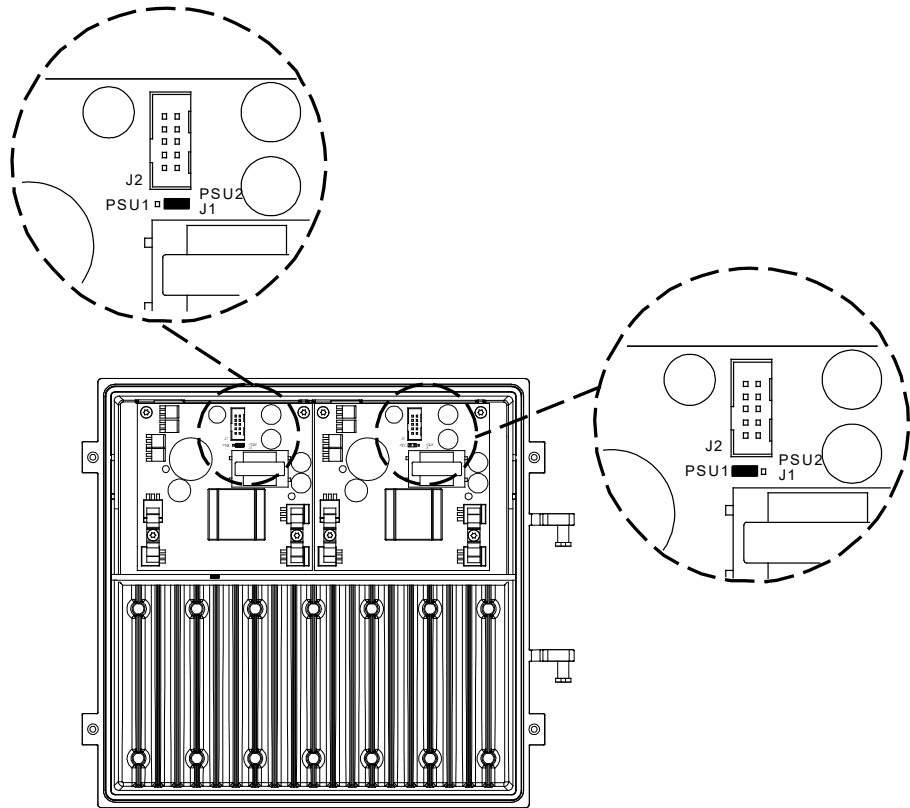

Figure 10. Diagram illustrating the AC8710 lid with both PSUs installed.

## Fibre installation

Fibre installation is a critical procedure and it should be done with carefulness. Incorrect handling of the fibres can result in damage and degraded performance.

### Cleaning fibre connectors

Always clean and inspect fibre adapters and connectors before connection. Keeping fibre optic end-faces clean is extremely important and one of the most critical requirements for ensuring proper operation.

We recommend to use only industry approved methods, materials, and solutions for cleaning optical connectors. There are a number of simple, effective products that are specifically designed for cleaning fibre adapters and connectors quickly and without the need for solvents.

When fibre optic connectors are unmated, the optical fibre end faces must be protected from contamination using suitable dust caps. Contamination of fibre end faces will reduce the performance of the optical fibre and could ultimately cause failure of the system. Contamination could also damage the fibre end faces when the connectors are mated.



**DANGER!** Do not look into the optical connector of the return transmitter with power applied. Laser light, visible or invisible, can seriously injure eyes or even cause blindness.

---

**Fibre management**

The outside plant fibre cabling is done through the base coupling. Gently route the incoming fibre around fibre retaining tabs on the base (Figure 11 pos. A). Ensure that no fibres are pinched while the lid is closed.

Integrated fibre organiser provide a convenient splicing and storing location for fibre pigtailed (Figure 11 pos. B). The fibre organizer is equipped with lid for further protection. Connectors and adapters are held in place in the fibre tray by universal type holders ensuring compatibility with variety of existing connectors and adapters.

8612038

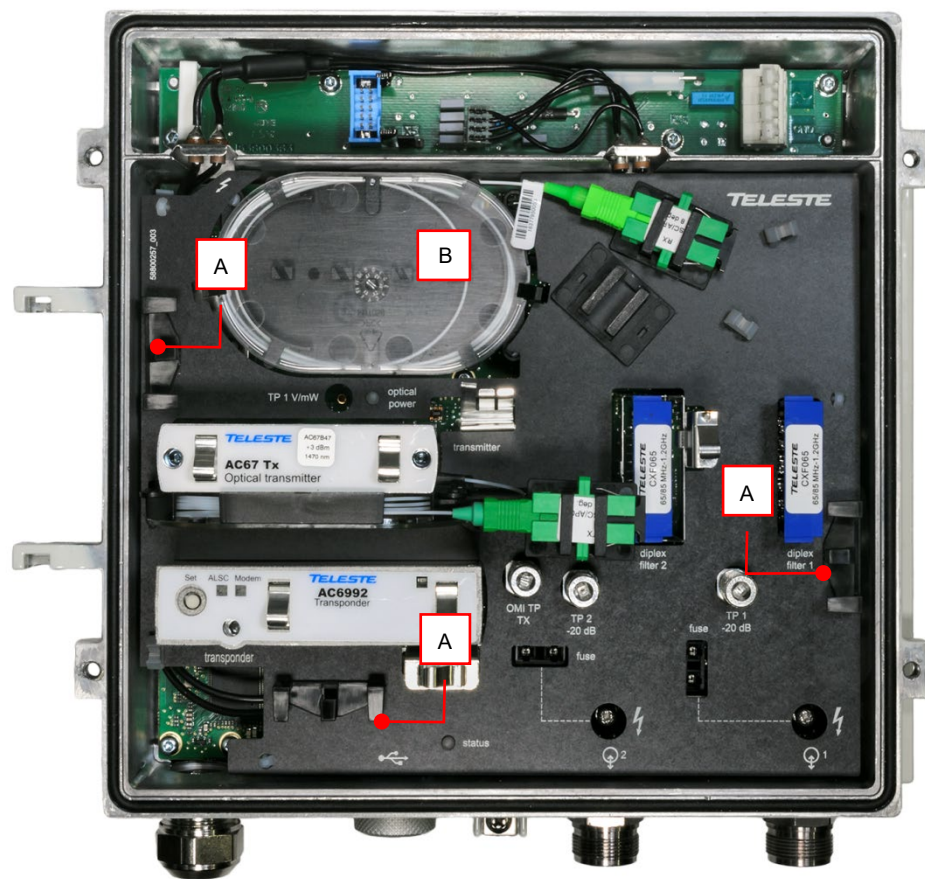

Figure 11. AC8710 - typical configuration

**Front panel**

8616062

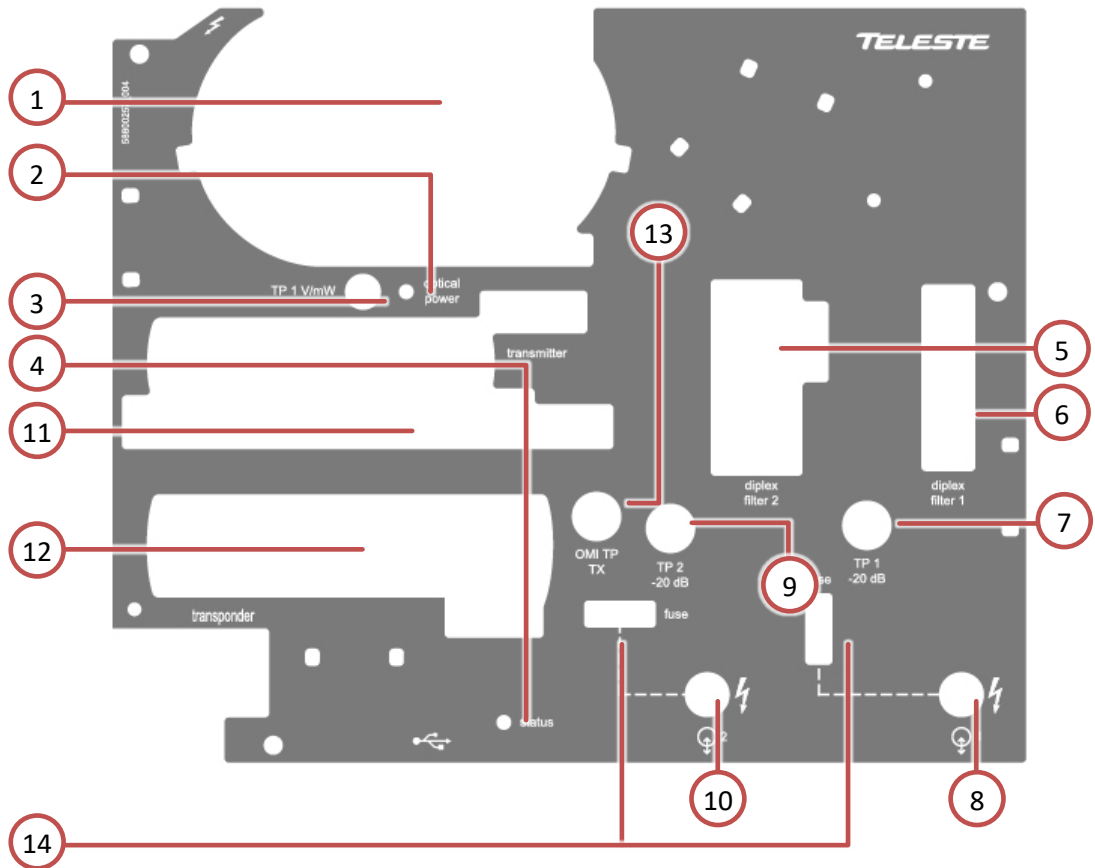

Figure 12. AC8710 front panel

- |  |  |
|--|--|
| 1) Integrated receiver with fibre organiser                    | 9) Output 2 test / injection point, -20 dB directional coupler |
| 2) Optical input power indicator LED                           | 10) Output 2   |
| 3) Optical power DC voltage test point                         | 11) Slot for optical transmitter                               |
| 4) Status indicator LED  | 12) Slot for transponder                                       |
| 5) Output 2 diplex filter                                      | 13) OMI test point for optical transmitter                     |
| 6) Output 1 diplex filter                                      | 14) Fuses  |
| 7) Output 1 test / injection point, -20 dB directional coupler |  |
| 8) Output 1  |  |

## Features

### Diplex filter modules

The installed diplex filters must have the same frequency range and they must be new 1.2 GHz types that are automatically detected by the software. The available diplex filter types are CXF065 (65/85 MHz), CXF085 (85/105 MHz), and CXF204 (204/258 MHz) and their high-pass versions (with "18/19" extension).

Diplex filters are automatically recognised by the software. This information is used for automatically controlling forward path high pass filtering and return transmitter bandwidth selection, which is set according to the highest frequency detected filter for all transmitters. "Unknown module" alarm is set if diplex filter type cannot be detected or diplex filter types mismatch.

Note that there are some special versions of the diplex filters, e.g. "CXF065 DA4" and "CXF204 UA6" which have built-in forward or return path attenuation or return path high-pass filtering. These diplex filters are detected as normal CXF065 / CXF204 respectively and the built-in attenuation is thus not taken into account in forward or return path automatic alignment. If these diplex filter types are used, their effect must be taken into account manually.

### Automatic alignment

AC8710 automatic alignment can perform several tasks during the installation or at a later stage of the AC8710 lifecycle by just pressing a single button. The automatic alignment allows true plug-and-play installation and can be user configured to the finest detail already at the factory.

The automatic alignment has to be enabled with a Product Key. It can run the following tasks when started with transponder "Set" button or via UI software:

- **Run forward path pilot based alignment** (default: enabled). The forward path gain and slope are aligned based on measured pilot levels and pre-configured pilot settings. ALC is enabled. Requires AC6981, AC6983 or AC6992 transponder to be installed.
- **Run forward path OMI based alignment** (default: disabled). The forward path gain is aligned based on preconfigured OMI and target level values.
- **Run forward path OMI based alignment** (default: disabled). The forward path gain is aligned based on preconfigured OMI and target level values.
- **Set reserve pilot target level to measured value** (default: disabled). Reserve pilot measurement value is stored as target value. Requires a transponder to be installed.
- **Set interstage gain minor alarm limits** with user specified offset to current value (default: disabled,  $\pm 3$  dB). Major alarms are not affected. After this the unit will alarm if the interstage gain control has been changed by ALC too much since installation, indicating a potential problem in input signal levels.
- **Set optical input power reference to measured value** (default: enabled). The unit memorises the measured optical input power during installation,

which can be later used to track changes in optical input power, possibly indicating potential problems in the network.

- **Set optical input power minor alarm limits** with user specified offset to measured input power (default: enabled,  $\pm 2$  dBm). Major alarms are not affected. After this the unit will alarm if the measured optical input power has changed too much since installation, indicating a potential problem in the optical link.
- **Set remote AC supply voltage minor alarm limits** with user specified offset to measured value (default: disabled,  $\pm 5$  Vrms). Not run if voltage is below 5 V, indicating local powering. Major alarms are not affected. After this the unit will alarm if the remote AC supply voltage has changed too much since installation, indicating a potential problem in remote powering.
- **Disable further automatic alignment** (default: disabled). Activated ~5 minutes after automatic alignment has completed successfully. After this, the automatic alignment cannot be restarted without first activating it via UI software.

During the alignment the transponder "ALSC" led will change colours fast. When the alignment has been completed, the led blinks for 5 s according to the result (see below) and then returns to its normal status.

- **Red blink:** Forward path alignment could not be started due to e.g. missing optical power or missing pilot signal. No further tasks are run, all controls return to their original values.
- **Yellow blink:** Forward or return path could not be adjusted properly due to gain out of range. Best effort adjustment is made and rest of the tasks are run. The user should check the resulting adjustment values.
- **Green blink:** Automatic adjustment completed successfully.

Detailed status information is available when the automatic alignment has been started via the UI software.

---

## Forward path

The output amplifier stages of AC8710 uses GaN hybrids which makes the usable output level range especially wide. The performance and power consumption of the RF stages can be adjusted according to the RF load and output level.

### Optical receiver

Optical receiver input power is measured and monitored.

The "Reference" field can be used to store the measured optical input power at installation time. It can be used to track changes over time.

### Forward path gain control

OLC is always enabled in AC8710. It adjusts input gain based on the measured optical input power so that output levels are stable and node performance is optimised.

In addition to the input gain controlled by OLC and not visible to the user, AC8710 has two gain control elements in its forward path signal route:

- **Interstage gain control for output 1**, adjustable in 0.1 dB steps between -15 and 0 dB.
- **Interstage gain control for output 2** is functionally identical but it follows output 1 with user specified offset, adjustable in 0.1 dB steps between -10 and +10 dB.

The forward path gain control elements and thus the resulting forward path output level can be controlled with two different adjustment methods:

- **Manual mode**, i.e. ALC disabled: Interstage gain can be adjusted by the user.
- **ALC mode**, available with transponders: The software adjusts interstage automatically gain based on pilot levels.

Regardless of the selected adjustment mode, output 1 slope, output 2 gain offset and output 2 slope offset values can be adjusted by the user.

### Forward path slope control

Forward path slope is adjusted with separate controls for both outputs in the same way than interstage gain. Output 1 is adjustable in 0.5 dB steps between 0 and 20 dB. Adjustment for Output 2 is functionally identical but it follows output 1 with user specified offset, adjustable in 0.5 dB steps between -10 and +10 dB.

### OLC offset

The "OLC offset" parameter value is added to the input gain value calculated from optical input power and can thus be used to adjust the balance between input and interstage gain controls if very low (or high) output levels are needed.

OLC offset is normally 0. If necessary, it is adjusted in 0.5 steps between -15 dB and +3 dB by pilot based or OMI based automatic alignment to optimise RF performance.

Note that positive OLC offset values cause minimum optical input power for OLC operation to increase by half of OLC offset value. For example: OLC operation range starts normally from -8 dBm, but with +2 dB OLC offset the OLC operation starts from -7 dBm.

### Power save

The RF performance and power consumption of AC8710 can be adjusted by controlling the output hybrids' current. The idea in this adjustment is that the node doesn't have to be better than the optical transmission path.

Power save is disabled as factory default. This ensures full performance and should be used if output levels are close to maximum. If output levels are more than 3 dB below maximum levels power save can be enabled without effect on RF performance. For example, with a full 1.2 GHz digital load and 8 dB sloped output this decision level is approximately 109 dB $\mu$ V.

### Pilots and ALC

Pilot measurements and ALC are supported by AC6981, AC6983, and AC6992 transponders.

AC8710 uses the transponder RF level measurement unit to sequentially measure signal levels of output 1 at user defined pilot frequencies and, if enabled, also the forward path spectrum and return path ingress frequencies. The measurement is done using narrow bandwidth (see transponder spec sheet) and then adjusted for the selected detector type and signal bandwidth.

Pilot measurements support 4 detector types:

- **Analog:** Peak detector optimised for CW or modulated analog signals.
- **EU QAM** ("Digital" in older software versions): Averaging detector optimised for European QAM signals.
- **US QAM** (only in new software versions): As "EU QAM" but accounts for the different channel bandwidth of American QAM signals.
- **OFDM** (only in new software versions): As "EU QAM" but adjusts for 6 MHz measurement bandwidth. Note that measuring an OFDM signal at the PLC area containing stationary pilots typically yields +0.5...1 dB higher measurement results.

ALSC (Automatic Level and Slope Control) in AC8710 adjusts only gain, not slope, thus the term ALC is also used. Forward path slope is automatically adjusted only during pilot based automatic alignment.

AC8710 has a high main pilot, a low main pilot and a high reserve pilot. The high pilot controls interstage gain. The low pilot is not used by ALC. It is only used for slope adjustment during pilot based forward path automatic alignment. Pilot target levels for all three pilots can be independently configured by the user.

If the high main pilot is lost, i.e. its level falls below user defined "Lost level", AC8710 uses the high reserve pilot for ALC and gives "ALC main pilot missing" alarm.

If both high main and high reserve pilots are lost, AC8710 gives "ALC all pilots missing" alarm and freezes the interstage gain control.

---

Setting low pilot frequency to 0 MHz will disable slope adjustment during pilot based forward path automatic alignment.

ALC keeps the output 1 signal level stable irrespective of input signal level variations by adjusting the interstage gain based on the pilot measurements. Gain is adjusted slowly in small steps to guarantee stable operation in long amplifier cascades. If output 1 interstage gain control is adjusted against its limit, AC8710 gives "ALC saturated" alarm and stops adjusting.

Output 2 follows output 1, i.e. its interstage gain control is adjusted so that the offset to output 1 interstage gain control remains unchanged. If output 2 interstage gain control is adjusted against its limit, AC8710 gives "ALC saturated" and stops adjusting.

If ALC drives interstage gain control over its low/high minor/major alarm limits, a corresponding alarm is activated. This can be used for early warning for potential problems in input signal levels. The minor alarm limits can be configured to be set automatically during automatic alignment.

---

### Forward path pilot based alignment

The forward path can be automatically aligned with a single command, provided that AC6981, AC6983 or AC6992 transponder is installed and the feature is enabled with correct Product Key. Correct pilot settings and output 2 gain and slope offset values need to be programmed, either at the factory or by the user.

If the low main pilot is enabled ( $f > 0$  MHz), it will be used for slope adjustment during pilot based alignment. If it is disabled ( $f = 0$  MHz), slope will not be adjusted during pilot based alignment.

Pilot based alignment can be included in the automatic alignment and can thus be activated with transponder front panel "Set" button. It can also be activated separately via the user interface.

The pilot based alignment adjusts OLC offset together with interstage gain and slope so that pilot targets are reached while simultaneously optimising node performance and making sure ALC has enough adjustment range.

Forward path pilot based alignment status is indicated by the "ALSC" led as described in the "Automatic alignment" chapter. The best effort adjustment is made if the targets cannot be fully reached.

Possible pilot based alignment error reasons and their explanations, which are displayed in the dialog box when the alignment is started via the user interface (see also Figure 12):

- **Pilot target out of range:** Main pilot target levels are outside 80...120 dB $\mu$ V range or high and low pilots have less than 200 MHz between them. Adjustment not started.
- **Optical input power out of range:** Measured optical input power is below -9 dBm. Adjustment not started.
- **Pilot not found:** Measured high main or low main pilot (if enabled) level is below 65 dB $\mu$ V. Pilot frequency may be incorrect. Adjustment not started.
- **Interstage slope out of range:** Calculated output 1 interstage slope is outside -1...20 dB range. Best effort adjustment made.
- **Interstage 2 slope out of range:** Calculated output 2 interstage slope is outside -1...20 dB range. Best effort adjustment made.
- **Gain out of range:** Calculated input gain is outside adjustment range or interstage gain 1 or 2 is less than 1 dB from adjustment range limit, not leaving room for ALC adjustments. Best effort adjustment made.

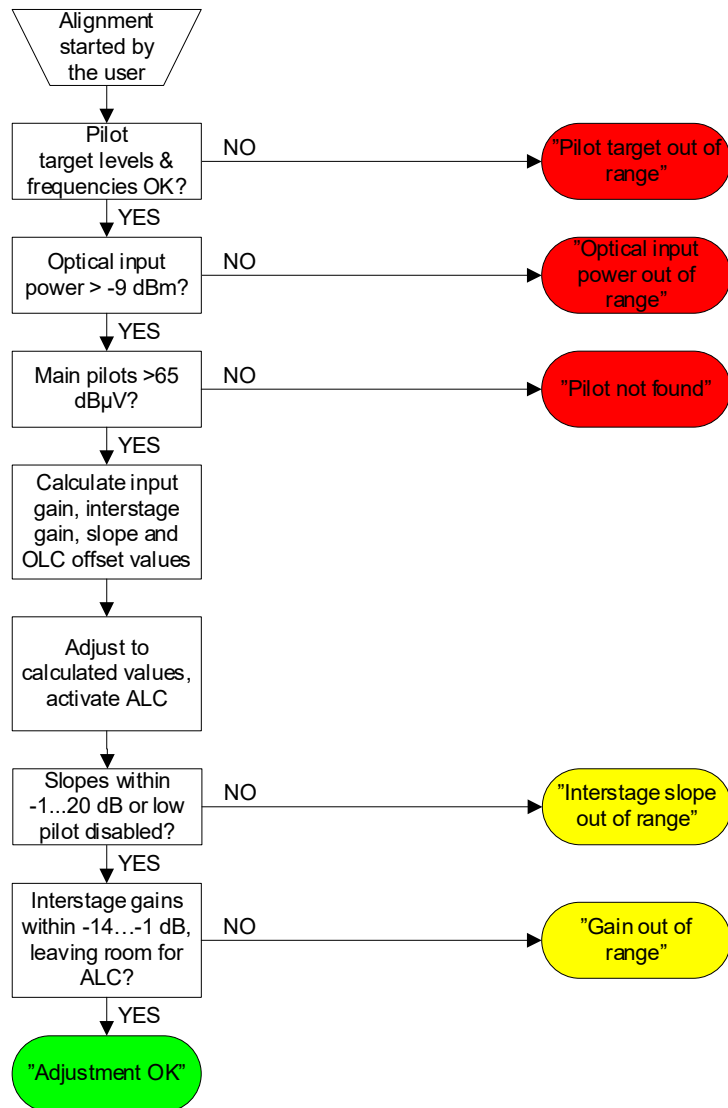

Figure 13. Simplified forward path pilot based alignment flowchart. Red = adjustment not started, yellow = best effort adjustment, green = targets reached

---

### Forward path OMI based alignment

Forward path can be also aligned based on the desired output 1 level and the OMI of the optical transmitter feeding forward path signal to AC8710. This feature does not need transponder module and Product Key activation.

The OMI based alignment adjusts OLC offset and interstage gain. Slope is not adjusted. OMI based alignment accuracy is typically worse than with pilot based alignment.

The transmitter OMI, output 1 target level and output 1 slope and output 2 gain and slope offset values need to be programmed, either at the factory or by the user.

If the alignment completes successfully, the calculated values are taken into use, otherwise all controls return to their original values.

Possible OMI based alignment error reasons and their explanations, which are displayed in the dialog box when the alignment is started via the user interface:

- **Optical input power out of range:** Measured optical input power is below -9 dBm.
  - **Gain out of range:** Calculated interstage gain values are outside the adjustment range.
-

## Spectrum analyser

Spectrum analyser is supported by AC6981, AC6983, and AC6992 transponders.

An AC8710 spectrum analyser can be used to measure and monitor output 1 forward path signals, provided that transponder is installed and the spectrum analyser feature is enabled with the correct Product Key. The measurement is done using narrow bandwidth (see transponder spec sheet) and then adjusted for the selected detector type and signal bandwidth.

Spectrum measurements support 4 detector types:

- **Analog:** Peak detector optimised for CW or modulated analog signals.
- **EU QAM** ("Digital" in older software versions): Averaging detector optimised for European QAM signals.
- **US QAM** (only in new software versions): As "EU QAM" but accounts for the different channel bandwidth of American QAM signals.
- **OFDM** (only in new software versions): As "EU QAM" but adjusts for 6 MHz measurement bandwidth. Note that measuring an OFDM signal at the PLC area containing stationary pilots typically yields +0.5...1 dB higher measurement results.

Up to 100 measurement frequencies with detector type and high/low minor/major alarm limits can be specified by the user.

Each measurement frequency can have up to 4 alarm limits. The measurement result is compared against its limits. When all frequencies have been measured the number of measurements exceeding their limits is compared to the "Tolerance" parameter and the "Spectrum warning" and "Spectrum alarm" statuses are updated. The "Tolerance" parameter can be used to fine-tune alarm sensitivity; default value 0 activates the alarm even if only one measurement result exceeds its limits.

"Spectrum alarm" is set if more than "Tolerance" values are above high major alarm limit or below low major alarm limit. "Spectrum warning" is set if more than "Tolerance" values are above high minor alarm limit or below low minor alarm limit and "Spectrum alarm" is not active.

There is a fixed 1 dB hysteresis to prevent alarm toggling: once activated, the alarm only goes off when the measurement result is within (limit – 1 dB).

## Return path

### Optical transmitters

Optical transmitter module has an internal pilot generator that can be controlled via user interface separately from the AC6992 transponder return path pilot generator. The optical module's pilot generator can be disabled or set to 5.5 MHz or 6.5 MHz.

Optical transmitter module laser bias current is measured and monitored.

The bandwidth setting of the optical transmitter modules is automatically set by the software according to highest-frequency detected duplex filter. If an unknown duplex filter is detected, the behaviour is as with CXF065.

Return path input 1 and 2 signals are combined and the combined signal is fed to the transmitter.

### Return path gain adjustment

Return path levels can be adjusted independently with the gain controls in 0.5 dB steps between -20 and 0 dB.

### Return path OMI based alignment

The return path OMI based alignment can be included in the automatic alignment and can be activated with transponder front panel "Set" button. It can also be activated separately via the user interface and does not require a transponder to be installed.

Note that the return path OMI based alignment is run only once and is thus not a "return path ALC", whereas the forward path can be aligned continuously depending on the selected "Adjustment mode".

Return path OMI based alignment adjusts input 1 and input 2 gain controls based on the target OMI-% of the optical transmitter and the estimated RF level at return path input ports. The target OMI and RF input level values need to be programmed either at the factory or by the user before starting the alignment.

A "best effort" alignment is made if target cannot be reached. This is indicated with "Gain out of range" status if OMI based alignment was started via the user interface, and transponder "ALSC" led will blinking in yellow if OMI based alignment was run as part of automatic alignment.

### Ingress control switches

Ingress control switches are independent for both inputs and can be used to attenuate return path or to cut it off completely. Ingress measurement and modem communication are not affected by ingress switches, thus it is possible to monitor incoming ingress and communicate with the node remotely even when return path is cut off.

The ingress switches are read-only if automatic ingress blocking is enabled.

### Automatic ingress blocking

When automatic ingress blocking (AIB) is enabled, ingress control switches are disabled from the user and the software operates them between 0 dB / attenuated / -50 dB based on the "Ingress alarm" and "Ingress warning" statuses and user-configurable delays.

AIB has 4 operation modes (only the first 2 available in older software versions):

- **Disabled:** No automatic ingress blocking. Ingress switch is in user control.
- **Alarm: Att:**
  - "Ingress alarm" active for "Activation delay" time → attenuate.
  - "Ingress alarm" off for "Deactivation delay" time → 0 dB.
- **Alarm: -50 dB:**
  - "Ingress alarm" active for "Activation delay" time → -50 dB.
  - "Ingress alarm" off for "Deactivation delay" time → 0 dB.
- **Warning: Att, Alarm: -50 dB:**
  - "Ingress warning" active for "Activation delay" time → attenuate.
  - "Ingress alarm" active for "Activation delay" time → -50 dB.
  - Both off for "Deactivation delay" time → 0 dB.

Activation and deactivation delays allow fine-tuning AIB operation and prevent unwanted switching on spurious signals. They should usually be selected so that delays are smaller deeper in the network.

The default attenuation value 6 dB can be adjusted separately for both inputs between 3 and 10 dB to fine-tune AIB.

### Ingress analyser

Ingress analyser is supported by AC6981, AC6983, and AC6992 transponders.

AC8710 ingress analyser can be used to measure and monitor return path signals, provided that transponder is installed and the ingress analyser feature is enabled with the correct Product Key. The measurement is done using narrow bandwidth (see transponder spec sheet) and then adjusted for the selected detector type and signal bandwidth.

Ingress measurements support 2 detector types:

- **Analog:** Peak detector with 5 measurement max hold.
- **Digital:** Averaging detector, see transponder spec sheet for bandwidth.

Up to 30 measurement frequencies with individual analog / digital detector (for signals/noise, respectively) selection and high warning / high alarm limits can be specified by the user. The measurement files containing frequencies, detector types and alarm limits can be specified separately for each input port.

Each measurement frequency can have both, either or no alarm limits. Each measurement result is compared against its limits. When all frequencies have been measured the number of measurements exceeding their limits is compared to "Tolerance" parameter and "Ingress warning" and "Ingress alarm" statuses are updated. The "Tolerance" parameter can be used to fine-tune

alarm sensitivity; default value 0 activates the alarm even if only one measurement result exceeds its limits.

"Ingress alarm" is set if more than "Tolerance" values are above high major alarm limit. "Ingress warning" is set if more than "Tolerance" values are above high minor alarm limit and "Ingress alarm" is not active.

There is a fixed 1 dB hysteresis to prevent alarm toggling: once activated, the alarm only goes off when the measurement result is within (limit – 1 dB).

Ingress measurement frequencies should be selected so that there are no other return path signals nearby. Selecting a measurement frequency close to other signals will affect the dynamic range of the ingress analyser. See transponder spec sheet for information on measurement bandwidth.

Ingress analyser alarm can also be used to trigger automatic return path ingress switch attenuation.

### **Transponder return path pilot generator**

AC8710 return path pilot generator can be activated when the AC6992 transponder is installed and the feature is enabled with Product Key.

There can be up to 4 user programmable pilot frequencies in the frequency range of 5...65 MHz (0.1 MHz steps). Pilot levels are specified at the transponder output as with modem transmit levels, and restricted to 75...100 dB $\mu$ V range. The UI displays resulting equivalent input level, i.e. the level at which a signal should be injected to return path input to appear at equivalent level with the generated pilot signal at return path output.

When the pilot generator is enabled, one of the pilot signals is output for user defined pilot duration, then switched to the next pilot signal and then repeated again. The duration parameter is ignored if only one pilot signal is activated.

Possible RF modem transmissions occur asynchronously, i.e. in the middle of any pilot transmission. Pilot output is switched off during modem transmission and resumes after the modem transmission has been completed. This causes typically less than 50 ms gaps in pilot transmission.

Pilot signals closer than 0.3 MHz from modem transmit frequency are not generated. Pilot signals can cause problems to modem communication if the pilot is close to modem frequency and pilot level is high compared to modem transmit level. Thus it is recommended to keep pilots at least 0.5 MHz from modem frequency.

Detection of these time domain multiplexed return path pilot signals can be accomplished at head end with e.g. a standard spectrum analyser instrument used in "Max hold" mode, or with another amplifier/node capable of return path signal measurement.

---

## Remote communication

The transponder module is used for remote communication. The software supports AC6981, AC6983 and AC6992 transponders and CATVisor, HMS and DOCSIS communication protocols.

With AC6992 it is possible to set the communication protocol to CATVisor or HMS via the user interface. CATVisor protocol is compatible with Teleste CATVisor Commander and Argus system. HMS protocol uses SNMP for remote communication and can thus be used also with Teleste CATVisor or 3rd party management software. It is possible to change between CATVisor and HMS also remotely. All modem related settings should be carefully reviewed before changing the protocol to avoid loss of remote communication.

With AC6981 and AC6983 the main remote communication protocol is SNMP. CATVisor protocol is also supported and thus e.g. CATVisor SmartLoader can be used.

The reported modem receive and transmit levels are measured at transponder RF input and output ports. Modem receive level is directly related to forward path output level. Modem transmit level vs. return path input level varies with return path gain as depicted in the technical specification.

Transponder "Modem" led is dark while the unit is scanning for communication channel and blinks while it is establishing the communication link. During normal communication the led colour is decided from modem-related alarms.

### **CATVisor modem functionality (AC6992)**

After reset the transponder starts scanning for HEC (HeadEnd Controller, e.g. Teleste HDM100 T) carrier within the user specified frequency range. When a communication channel is found, it waits for registration slot and sends its registration request. If the HEC accepts the registration, transponder enters normal communication mode where it is periodically polled by the HEC.

If the registration fails, or transponder is in normal communication mode but doesn't receive any packets from the HEC it starts scanning again. During registration the HEC sends communication parameters such as transmitter frequency and transmitter level.

All communication between the transponder and CATVisor Commander, Argus, or SmartLoader is done with UDP/IP packets via the HEC. This means that transponder IP address has to be unique and match HEC's subnet settings.

### **HMS modem functionality (AC6992)**

HMS mode is similar to CATvisor mode. The transponder scans for HMTS (Hybrid Management Termination System, e.g. Teleste HDM100 H) carrier. Transmit level is not set by the HMTS and thus has to be adjusted manually. In HMS the behaviour when forward communication is lost is controlled by the HMTS settings.

For details on HMS modem functionality, please refer to HMTS documentation and HMS standards.

---

**DOCSIS modem functionality (AC6981/AC6983)**

AC6981 and AC6983 transponders act as a standard DOCSIS cable modem. There are no communication settings available for user, everything is done automatically as commanded by the CMTS (Cable Modem Termination System). Depending on the CMTS and headend LAN settings it is usually necessary to configure the transponder MAC address to DHCP server and allow SNMP (UDP ports 161 and 162) and CATVisor (UDP port 2500) traffic to transponders. The SNMP community strings and other DOCSIS related settings are configured via DOCSIS configuration file as with other cable modems.

It is recommended to allocate dedicated DOCSIS channels for transponder communication. These channels should use more robust modulation than regular channels, for example QAM16 in forward path and QPSK in return path. This helps in keeping the transponders online even if there is massive ingress preventing normal cable modem communication.

---

## Establishing a connection

All the needed configurations and adjustments can be carried out locally or remotely by using the CATVisor Commander software. Detailed CATVisor Commander hardware requirements and installation instructions can be found in the User Manual supplied with Commander.

Connection to AC8710 is possible using the following methods:

### Local configuration with a PC

Connection to AC8710 USB port can be done with a standard USB A plug to USB mini B plug cable, or via AC6901 USB to Bluetooth adapter. The cable or adapter should be disconnected when not in use to avoid possible EMC problems caused by the cable acting as an antenna.

AC8710 will draw power from the USB connector for its microcontroller and memory if no external power supply is available. This makes it possible to configure AC8710 settings and update the software without any power supply.

Note that as only the CPU part of the unit is powered via USB, many parameters visible via the user interface may display incorrect values. Installing and removing plug-in modules while the unit is USB powered is not recommended and may lead to unexpected behaviour.

### Local configuration with an Android device

Teleste Commander software for Android devices can be downloaded from Google Play. Connection to AC8710 USB port can be done via AC6901 USB to Bluetooth adapter. The adapter should be disconnected when not in use to avoid possible EMC problems caused by the adapter acting as an antenna.

### Remote CATVisor connection

Remote IP connection via a HEC (e.g. Teleste HDM100 T) with AC6992 transponder. Transponder IP address has to be correctly set before remote IP communication is possible. It has to match the subnet settings of the HEC's HFC network interface and it must also be unique for each transponder.

Note that it is also possible to set the IP address remotely via the HEC, see HEC documentation for details.

### Remote HMS connection

Remote SNMP connection via an HMTS (e.g. Teleste HDM100 H) with AC6992 transponder. AC8710 can be accessed remotely using an SNMP Manager application. Usually, there is no need to pre-configure any communication parameters to establish a connection with the HMTS. However, the selected installation procedure may include pre-setting e.g. the IP address, transmit level and the forward path frequency scanning limits.

### Remote DOCSIS connection

Remote SNMP connection via a CMTS with AC6981 or AC6983 transponder. AC8710 can be accessed remotely using an SNMP Manager application or CATVisor Commander. The CMTS system must be preconfigured to accept the transponder and the used protocols.

---

## Alarms

The module alarms, also known as "flags", displayed in CATVisor Commander and Argus are described in the table below. Equivalent SNMP traps and alarms are also available via a remote connection with HMS and DOCSIS protocols.

The affected led and factory default severity settings are presented next to each alarm in Table 3. All alarm severities (Major / Minor / Notification / Disabled) and alarm limits can be fully configured by the user. See the 'Monitoring' chapter for more details.

Note that some alarm limits (for example remote AC supply voltage) are factory configured so that alarms will only appear when hardware specifications are exceeded. The alarm limits should be reconfigured to match network parameters if more precise monitoring is needed.





Analog alarm	Description & suggested corrective action	Led	Default severity
Temperature high	Temperature is above high limit.	Status	Major & Minor
Temperature low	Temperature is below low limit.	Status	Minor
AC voltage high	AC voltage is above high limit.	Status	Minor
AC voltage low	AC voltage is below low limit. As some units are equipped with mains power supply, this alarm is disabled as factory default and should be enabled by the user if AC voltage is to be monitored.	Status	Disabled
+24V voltage high	+24V voltage is above high limit. Common for both power supplies.	Status	Major & Minor
+24V voltage low	+24V voltage is below low limit. Common for both power supplies.	Status	Major & Minor
+12V voltage high	+12V voltage is above high limit.	Status	Major & Minor
+12V voltage low	+12V voltage is below low limit.	Status	Major & Minor
Optical Rx level high	Optical receiver power level is above high limit.	Optical power	Major
Optical Rx level low	Optical receiver power level is below low limit.	Optical power	Major
Optical Tx laser current high	Optical transmitter laser current is above high limit.	Status	Minor
Optical Tx laser current low	Optical transmitter laser current is below low limit.	Status	Minor
Modem receive level high	RF modem receive level is above high limit. Generated only if AC6992 transponder is installed and modem is connected.	Modem	Minor
Modem receive level low	RF modem receive level is below low limit. Generated only if AC6992 transponder is installed and modem is connected.	Modem	Minor
Interstage gain high	Interstage gain control is driven above high limit by ALSC.	ALSC	Minor
Interstage gain low	Interstage gain control is driven below low limit by ALSC.	ALSC	Minor
Discrete alarm	Description & suggested corrective action	LED	Default severity
Unknown module	Device is not able to recognise diplex filter or transponder module(s), or diplex filter types do not match. Possible reason is wrong module type, malfunction or bad installation of a plug-in module. If unit software is up to date and removing and reinstalling the plug-in modules doesn't help, contact Teleste support.	Status	Major
Internal error	Device has an internal error. If resetting the unit doesn't help, contact Teleste support.	Status	Major

Lid open	Transponder's light sensor light level has been above limit during last minute. Generated only if transponder is installed.	Status	Notification
Return path off	Return path is turned off by user. Common for both return paths.	Status	Notification
Return path attenuated	Return path is attenuated, either by user or automatically due to ingress. Common for both return paths.	Status	Notification
Settings changed	Unit's settings have been modified by user during last minute.	Status	Notification
Application started	Unit was reset or rebooted during last minute.	Status	Notification
Application updating	Unit or plug-in module software is being updated. No changes should be made to powering, plug-in modules or settings during software update.	Status	Minor
Service terminal connected	There has been activity on local USB connector during last minute.	Status	Notification
Modem not connected	RF modem is not connected. Generated only if transponder is installed.	Modem	Notification
Modem transmit level saturated	Commanded transmit level is outside transponder's allowed range, transmit level is saturated. Generated only if AC6992 transponder is installed, modem is connected and min < max.	Modem	Notification
Tuner module error	Internal error in transponder's level measurement unit. If resetting the unit doesn't help, contact Teleste support.	Status	Major
ALC all pilots missing	All pilots are missing. Generated only if transponder is installed and ALC is enabled	ALSC	Major
ALC saturated	ALC is saturated, i.e. gain adjustment limits have been reached. Generated only if transponder is installed and ALC is enabled.	ALSC	Minor
ALC main pilot missing	Main pilot is missing, ALC uses reserve pilot. Generated only if transponder is installed and ALC is enabled.	ALSC	Notification
ALC off	Transponder is installed but ALC is switched off by user. Or ALC is switched on by user but transponder is missing.	ALSC	Notification
Spectrum warning	Spectrum analyser measurements are outside minor alarm limits.	Status	Minor
Spectrum alarm	Spectrum analyser measurements are outside major alarm limits.	Status	Major
Spectrum out of limits	Spectrum analyser measurement results are not within high/low limits.	Status	Minor
Ingress 1 warning	Return path ingress measurements of port 1 are outside minor alarm limits.	Status	Minor
Ingress 1 alarm	Return path ingress measurements of port 1 are outside major alarm limits.	Status	Major
Ingress 2 warning	Return path ingress measurements of port 2 are outside minor alarm limits.	Status	Minor
Ingress 2 alarm	Return path ingress measurements of port 2 are outside major alarm limits.	Status	Major
Powered from USB	Processor powered from USB, rest of motherboard not alive.	Status	Notification

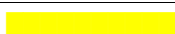

Table 3. AC8710 alarms

## Led usage







Modem related alarms are indicated with transponder "Modem" LED, ALC related alarms are indicated with transponder "ALSC" LED, other alarms are indicated with AC8710's Status LED with the exception of optical alarms which are indicated with optical input power led. The affected led and factory default severity settings are presented next to each alarm in Table 4. Alarms with "notification" severity do not affect LEDs.

Status led	Description
 red	≥1 major alarm (other than modem/ALC/OptRx)
 yellow	≥1 minor alarm but no major alarms
 green	No alarms (other than modem/ALC/OptRx)
 red blink	Software cannot start
 dark	Software/CPU/power failure

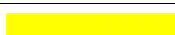
Optical receiver leds	Description
 red	Optical power high major alarm
 yellow	Optical power low major alarm
 green	Optical power within major alarm limits

ALSC led (AC698x, AC699x)	Description
 red	ALC enabled, ≥1 major alarm
 yellow	ALC enabled, ≥1 minor alarm
 green	ALC enabled, no alarms
 multicolour	Automatic alignment running
 green blink	Automatic alignment completed successfully
 yellow blink	Automatic alignment targets not fully achieved
 red blink	Automatic alignment stopped due to an error
 dark	ALC off





Modem led (AC699x) DOCSIS led (AC698x)	Description
 red	Modem connected, ≥1 major alarm
 yellow	Modem connected, ≥1 minor alarm
 green	Modem connected, no alarms
 green blink	Modem registering
 dark	Modem not connected

Table 4. AC8710 and transponder LEDs

## Product key activation of advanced features

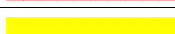
Some AC8710 features need to be activated with the correct product key:

- Automatic forward and return path alignment
- Forward path spectrum analyser
- Return path ingress analyser with automatic ingress control and filtering
- Return path pilot generator (AC6992 transponder)

The activation can be done when ordering the product and also later by contacting Teleste support. CATVisor Commander user manual provides more details on entering the product key.

## Transferring AC8710 settings

All user accessible settings are stored on the motherboard memory. Thus plug-in modules can be changed without losing any settings.

A “Settings Saver” DLL component for AC8710 is included in the latest DUS100 viewer packet release. It can be used with CATVisor Commander and CATVisor SmartLoader to transfer partial or complete device settings between a file and AC8710. This feature can be accessed through Commander > “Tools” > “Load/Save element configuration” when it has been activated with the correct serial number. SmartLoader supports also transferring settings from/to multiple units simultaneously.

Note that the Settings Saver component uses CATVisor protocol and cannot thus be used remotely with SNMP.

The settings are stored as \*.ECML files in XML format. These files can be also edited with standard text editors, provided that the XML tags and structure are maintained. Tags can be removed to create partial settings files. This makes it easy to download e.g. new pilot target levels to multiple units simultaneously.

The settings saver ECML files can also be edited in user-friendly format with an Excel tool. This tool can be downloaded from the Teleste extranet (MyTeleste). The settings saver ECML files can also be used for specifying factory settings when ordering preconfigured AC8710 units.

AC8710 will draw power from the USB connector for its microcontroller and memory if no external power supply is available. This makes it possible to configure AC8710 settings and update the software without any power supply.

Note that as only the CPU part of the unit is powered via USB, many parameters visible via the user interface may display incorrect values. Installing and removing plug-in modules while the unit is USB powered may lead to unexpected behaviour.

Settings download and upload is possible only to installed and enabled modules. This means that e.g. it is not possible to read the pilot settings of a missing optical transmitter module, or write certain transponder settings if correct transponder type is not installed.

Downloading device settings containing modem parameters over remote connection may cause loss of remote connection. Thus some settings may be not

written correctly. If modem parameters need to be written remotely, it is recommended to put them into a separate ECML file which is transferred separately after other settings.

---

---

## Updating AC8710 software

New software versions for AC8710 are published on the Teleste extranet (MyTeleste). These may contain bug fixes, enhancements, and completely new features. For details see "AC8710 software release history" document also available in MyTeleste.

Note that due to hardware changes different software files are needed for 1st gen and 2nd gen AC8710. 1st gen AC8710 is compatible with software versions 4.x.x, whereas 2nd gen AC8710 is compatible with software versions 6.x.x. 1st gen AC8710 does not accept 2nd gen AC8710 software, or vice versa.

AC8710 software can be updated locally via USB using CATVisor Commander or remotely via modem connection using CATVisor Commander, SmartLoader or 3rd party download tool. AC8710 stays fully operational during the update, i.e. RF paths are not affected, ALC continues to operate etc. The "Application updating" alarm is active during the update.

The new software is taken into use after it has been completely downloaded and the device is reset. The reset takes a couple of seconds after which the device is fully functional and running the new software. If the download fails, AC8710 continues to use its previous software.

### Local update

AC8710 software can be updated locally via USB using CATVisor Commander or Teleste Commander for Android devices. Local software update of AC8710 takes ~1 minute.

AC8710 will draw power from the USB connector for its microcontroller and memory if no external power supply is available. This makes it possible to configure AC8710 settings and update the software without any power supply.

### Remote update – CATVisor

Remote update for CATVisor is done using CATVisor Commander or SmartLoader. It is also possible to download new software to multiple devices simultaneously without resetting them and take the new software into use later by sending a broadcast reset with CATVisor SmartLoader.

### Remote update – HMS

Remote update for HMS is done using SNMP protocol with CATVisor Commander or other software tool supporting standard HMS-DOWNLOAD-MIB.

### Remote update – DOCSIS

AC8710 software can be updated remotely with either CATVisor or HMS protocols as described above.

## Updating transponder software

Some transponder types have their own software which handles the pilot measurements and/or remote communication. This software can be updated locally or remotely by using the methods above.

---

When transponder software update has completed, it can take up to 1 minute for the software to be taken into use. Wait until the new software version appears in the user interface before removing power or the transponder.

#### **AC6981, and AC6983 transponder DOCSIS software update**

AC6981, and AC6983 transponders have DOCSIS software which handles the remote communication. This software can be updated using standard DOCSIS methods, i.e. TFTP file download initiated by DHCP server configuration.

## **SNMP MIBs**

The parameters of a unit in HMS or DOCSIS mode can be accessed remotely using SNMP MIBs (Management Information Base). Should they be needed for e.g. integration with 3rd part management systems, the Teleste-proprietary MIBs are available for download in Teleste extranet (MyTeleste). SCTE MIBs can be downloaded from SCTE website.

Supported MIBs for AC8710:

- RFC1213-MIB
- TELESTE-ROOT-MIB
- TELESTE-ACX-MIB
- TELESTE-COMMON-MIB
- TELESTE-HMSMODEM-MIB
- TELESTE-ANALYSER-MIB
- TELESTE-PILOTGENERATOR-MIB
- TELESTE-FUNCTIONAL-COMMON-MODEM-MIB
- TELESTE-FUNCTIONAL-AUTOMATIC-ALIGNMENT-MIB
- TELESTE-ALARMS-MIB
- TELESTE-CM-CONFIG-MIB
- SCTE-ROOT
- SCTE-HMS-COMMON-MIB
- SCTE-HMS-PROPERTY-MIB
- SCTE-HMS-ALARMS-MIB
- SCTE-HMS-RFAMPLIFIER-MIB
- SCTE-HMS-FIBERNODE-MIB
- SCTE-HMS-DOWNLOAD-MIB
- Standard DOCSIS MIBs with AC6981 and AC6983 transponders

## Viewer pages

This chapter presents AC8710 viewer pages used with local or remote CATVisor protocol connection. Some of the viewer pages used with SNMP remote connection with HMS or DOCSIS protocols are slightly different in layout but contain the same parameters.

The viewer pages used to control AC8710 using CATVisor Commander or Argus are explained in this chapter. For a complete description of each feature, see corresponding "Features" chapter.

Some features may be greyed out, indicating that they can not be used at the moment due to e.g. missing plug-in module.

AC8710 viewer pages in CATVisor Commander/Argus:

- Status
- Forward path
- Return path
- Transponder (different pages for CATVisor / HMS / DOCSIS)
- Spectrum
- Ingress
- Properties

Some viewer pages have fields with coloured backgrounds, e.g. "Temperature" on "Status" page. These colours indicate the alarms related to this field. Green means no alarms or notifications; red is major alarm, yellow is minor alarm and blue is notification.

---

**Status viewer page**

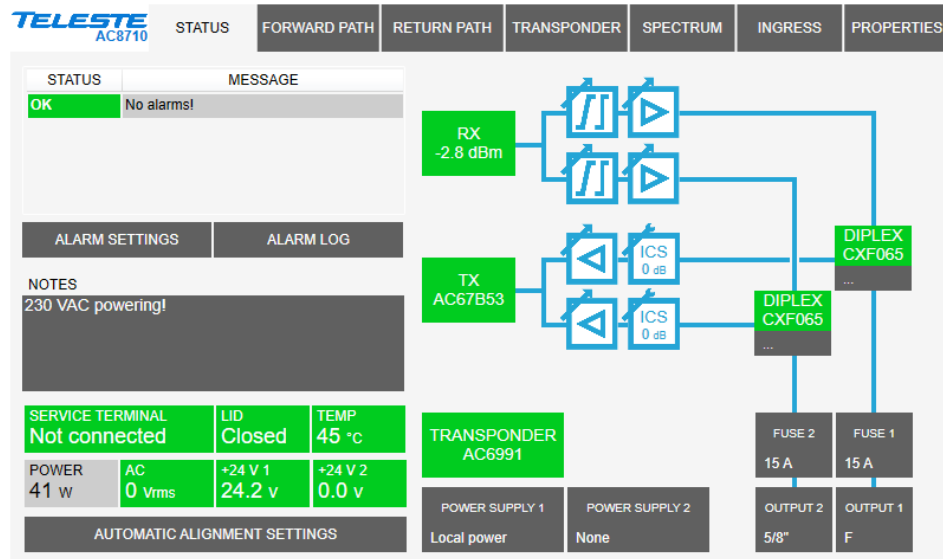

Figure 14. The Status page

The “Status” page displays unit's alarm list together with measurement data and a graphical view of the current configuration similar to the actual station layout.

**Alarm list, settings, and log**

Each alarm in the alarm list on the top left corner is colour coded according to its severity. Alarm limits and severities can be configured through the "Alarm settings" dialog (see below), opened with "Alarm settings" button. The "Alarm history" dialog (see below) can be opened with the "Alarm log" button. For additional information about alarms, see the table of module alarm descriptions in the "Alarms" chapter.

**Notes**

The “Notes” field allows storing up to 200 character message into AC8710 non-volatile memory. It can be used e.g. as a reminder for the pilot settings.

**Measurements**

The background colour of each field shows the parameter's alarm status.

The “Service terminal” field shows whether there has been activity on the local USB service connector during the last minute.

Lid status information is based on a light sensor in the transponder's front panel. "Lid open" is displayed if light level has been above limit during the last minute. In dark environment "Lid closed" may be displayed even if the lid is open

AC8710's internal temperature is typically 10...25 °C above ambient temperature depending on installation.

The "Power" field displays the estimated total power consumption of the unit based on the installed modules, power supplies, supply voltage and selected operating modes.

The "AC voltage" field shows true RMS value (DC+AC component) of the remote supply voltage. This value is calculated using a sliding average and thus reacts quite slowly to changes. The default limit values are based on AC8710's power supply specifications and are thus quite broad. They should be adjusted to match the network's AC supply voltage.

+12 V and +24 V factory default alarm limits are based on power supply specifications and usually shouldn't be altered.

### Automatic alignment settings

Transponder front panel has a "Set" button which starts automatic alignment. Clicking the "Automatic alignment settings" button on "Status" page opens a dialog for configuring the automatic alignment behaviour. The automatic alignment can also be started with the "Start automatic alignment" button in the settings dialog. For more information see "Features/Automatic alignment" chapter.

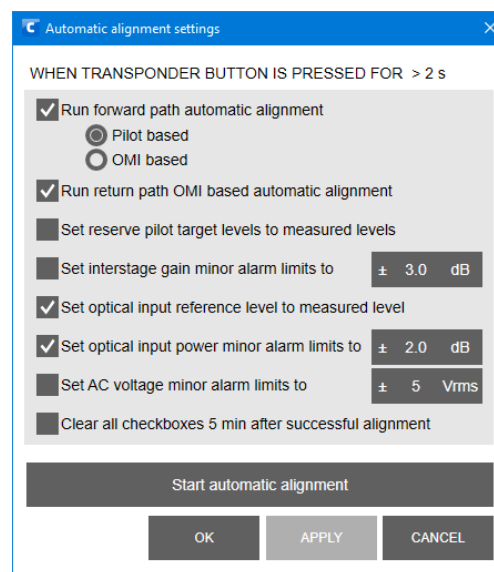

Figure 15. The Automatic alignment settings dialog

### Station layout

The optical transmitter, transponder and diplex filter modules are detected automatically and represented as boxes with background colour reflecting alarm status. Some modules (fuses, connectors, special diplex filter versions and power supplies) cannot be detected automatically. These are presented with grey boxes. Selecting a text tag representing a passive device will open a pull down selection list in which an appropriate device according the assembly can be selected. The user can also type in the desired information (up to 12 characters, 6 characters for fuses). The information entered in these fields does not affect unit operation in any way, it's just a "checklist".

See the "Features" chapter for details on plug-in modules and configuration.

## Alarm settings dialog

The "Alarm settings" button on "Status" page opens the alarm settings dialog.

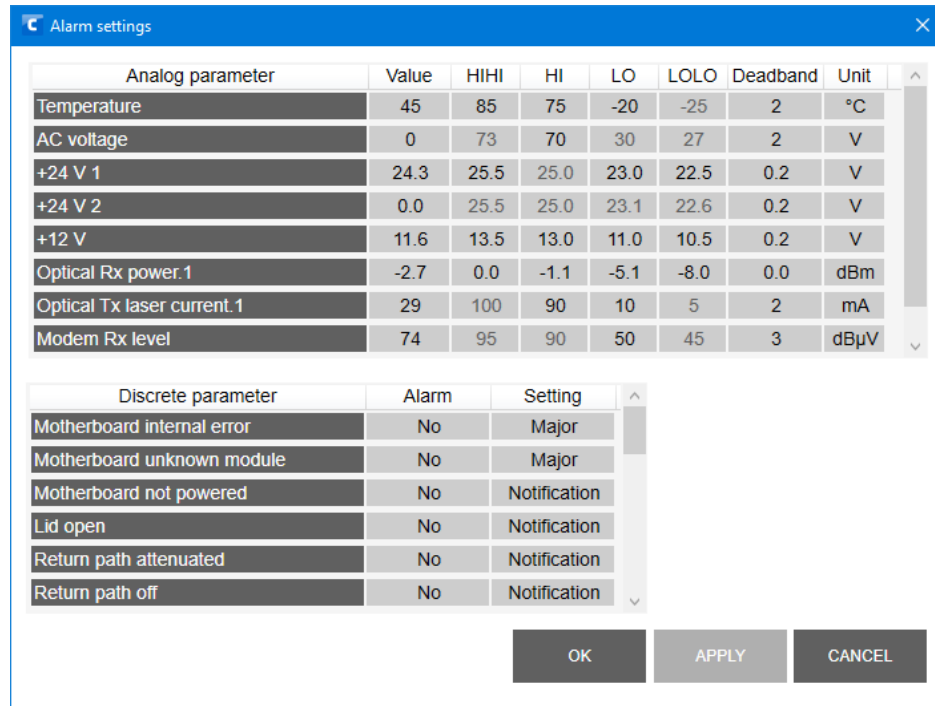

Figure 16. The Alarm settings dialog

The "Alarm settings" dialog displays all monitored parameters and their values as well as alarm limits, statuses, and severity settings.

See the "Alarms" chapter for descriptions of individual AC8710 alarms.

## Analog parameters

Each monitored analog parameter of the unit is displayed in the upper half of the dialog with the following information in the list:

- **Analog parameter:** Name of the monitored parameter, with background colour indicating active alarm.
- **Value:** Current measured value.
- **HIHI:** High major alarm limit
- **HI:** High minor alarm limit.
- **LO:** Low minor alarm limit
- **LOLO:** Low major alarm limit.
- **Deadband:** Specifies how much the measured value has to be on the "safe" side of the alarm limit before turning off the alarm.
- **Unit:** Unit of the measured parameter.

The alarm settings can be configured by double-clicking an analog parameter name. This will open a dialog box with parameter's alarm limits and deadband.

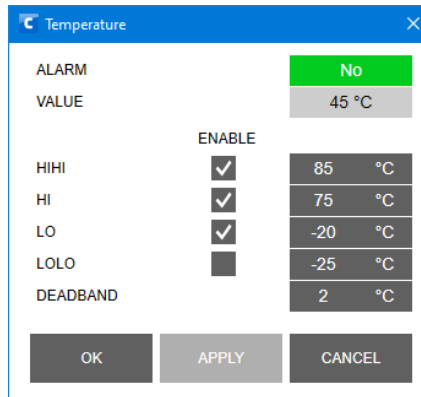

Figure 17. The analog alarm configuration dialog box

Each alarm limit can be individually enabled/disabled and configured. The alarm limits should be in decreasing order for correct alarm processing, preferably with more than "Deadband" units between each limit.

**Discrete parameters**

Each monitored discrete parameter of the unit is displayed in the lower half of the dialog with the following information in the list:

- **Discrete parameter:** Name of the monitored parameter, with background colour indicating active alarm.
- **Alarm:** Alarm status of the parameter: No/Notification/Minor/Major. If the alarm is disabled, but parameter is in alarming state, "Yes" is shown.
- **Setting:** Alarm severity can be configured to Major, Minor, Notification, or Disabled.

The alarm severity setting is user-configurable by double-clicking a discrete parameter name. This will open a dialog box that can be edited by users with at least "Service" level user rights. For others, this is read-only information.

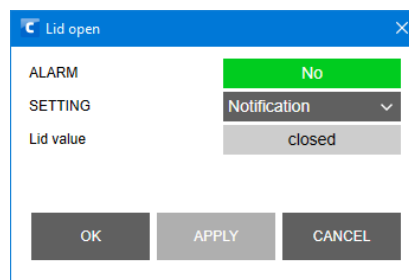

Figure 18. The discrete alarm configuration dialog box

**Alarm log dialog**

The "Alarm log" button on "Status" page opens the alarm log dialog.

INDEX	DATE	TIME	RESET#	PARAMETER	ALARM	DEVICE STATE
7570	Tue 27.4.2021	13.27.57	88	Settings changed	Notification	Nominal
7571	Tue 27.4.2021	13.28.57	88	Settings stable	No	Nominal
7572	Tue 27.4.2021	13.33.03	88	ALC on	No	Nominal
7573	Tue 27.4.2021	13.33.03	88	Settings changed	Notification	Nominal
7574	Tue 27.4.2021	13.34.03	88	Settings stable	No	Nominal
7575	Tue 27.4.2021	13.46.35	88	Lid closed	No	Nominal
7576	Tue 27.4.2021	14.31.39	88	Spectrum warning	Minor	Minor
7577	Tue 27.4.2021	14.31.43	88	Spectrum OK	No	Nominal
7578	Tue 27.4.2021	15.37.25	88	Modem not connected	Notification	Nominal
7579	Tue 27.4.2021	16.10.53	88	Modem connection OK	No	Nominal
7580	Mon 3.5.2021	12.10.41	88	Settings changed	Notification	Nominal
7581	Mon 3.5.2021	12.11.55	88	Settings stable	No	Nominal
7582	Mon 24.5.2021	19.10.09	88	ALC main pilot missing	Notification	Nominal
7583	Mon 24.5.2021	19.11.39	88	ALC pilots OK	No	Nominal
7584	Mon 24.5.2021	19.12.27	88	ALC main pilot missing	Notification	Nominal
7585	Tue 25.5.2021	14.50.37	88	ALC pilots OK	No	Nominal
7586	Tue 25.5.2021	14.52.17	88	ALC main pilot missing	Notification	Nominal
7587	Tue 25.5.2021	14.53.07	88	ALC pilots OK	No	Nominal
7588	Thu 27.5.2021	17.43.03	88	ALC main pilot missing	Notification	Nominal
7589	Thu 27.5.2021	17.44.37	88	ALC pilots OK	No	Nominal

NUMBER OF ENTRIES: 64    LAST INDEX: 7589    [SAVE]    [CLEAR AND REGENERATE]    [CLOSE]

Figure 19. The Alarm log dialog

The "Alarm log" dialog box displays the alarm history for the latest 64 events. The list is stored in non-volatile memory. All entries are date and time stamped with the most current entry at the bottom. Note that date/time information may not be correct for events that occurred before latest reset.

The total number of entries in the alarm log list is shown in the "Number of entries" field. The index number of the last entry is displayed in the accompanying field. Total number of entries is limited to 64. The oldest entry is overwritten when the log becomes full.

To save "Alarm log" page to a file, click the "Save" button.

The "Clear and regenerate" button clears the log and restarts alarm detection.

## Forward path viewer page

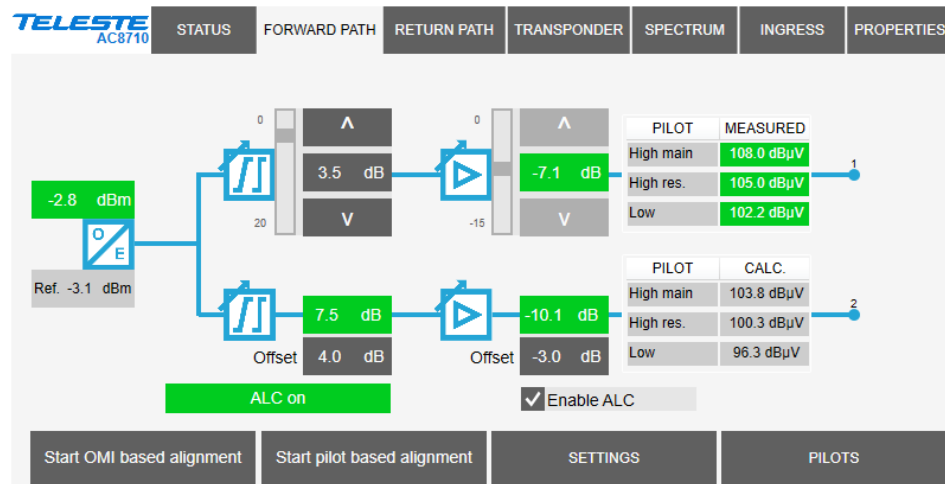

Figure 20. The Forward path page

The "Forward path" page displays all forward path settings.

### Optical receiver

The optical receiver and measured optical input power and reference level are displayed on the left-hand side of the page. The background colour of the optical input power field changes according to related alarms.

### Gain and slope controls

The middle part of the "Forward path" viewer page contains the gain and slope controls, which can be adjusted by clicking the up and down buttons or typing a value into the fields. The slider indicates the relative position of the control to its limits. When ALC is enabled the gain is read-only and controlled by ALC. The background colour shows gain alarm status.

Output 2 controls follow output 1 changes with the offset values specified in the "Offset" fields. The resulting gain and slope for output 2 are shown as read-only information with a green background when the value is within adjustment range and with a yellow background when the adjustment has saturated. The maximum range for both offset values is -10...10 dB.

### Adjustment mode and status

The adjustment mode (Manual / ALC) can be selected with the "Enable ALC" checkbox. The adjustment mode and possible ALC alarms are displayed in the status field at the bottom of the page with a background colour indicating alarm status:

- **ALC off:** ALC is disabled, gain can be adjusted.
- **ALC on:** ALC is enabled and works OK, interstage gain is read-only.
- **ALC saturated:** ALC is enabled but saturated and cannot adjust, i.e. output 1 or 2 interstage gain is adjusted to limit.
- **ALC main pilot missing:** ALC is enabled but main pilot is missing. ALC uses reserve pilot.

- **ALC all pilots missing:** ALC is enabled but pilots are missing. ALC is frozen, i.e. interstage gain is not adjusted.
- **No transponder:** ALC is enabled but transponder is not installed.
- **Tuner module error:** ALC is enabled but cannot adjust due to internal error in transponder tuner module.

## Outputs

The right-hand side of the "Forward path" viewer page displays the measured pilot levels for output 1 and calculated pilot levels for output 2. Measured pilot level background is red if the pilot is lost, green when the level is within  $\pm 1$  dB from the target level, otherwise yellow, or "N/A" in grey if transponder is not installed or the pilot is disabled.

## Start OMI based alignment

Clicking the "Start OMI based alignment" button starts forward path OMI based alignment. The adjustment parameters have to be set correctly via the "Settings" dialog before the adjustment is started. A dialog box is opened which displays the status of the alignment.

## Start pilot based alignment

Clicking the "Start pilot based alignment" button starts forward path pilot based alignment, provided that transponder is installed and the automatic alignment feature is enabled with the correct Product Key. The pilot settings have to be set correctly via the "Pilots" dialog before the adjustment is started. A dialog box is opened which displays the status of the alignment.

## Settings

The "Settings" buttons opens a dialog box (Figure 21) for configuring forward path settings.

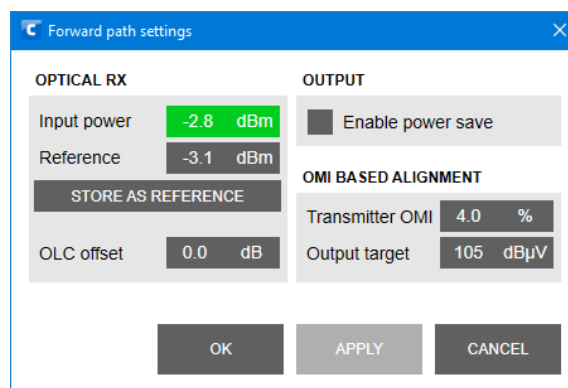

Figure 21. The Forward path settings dialog

## Optical receiver

The "Reference" field can be edited to store the optical input power value for future reference. The "Store as reference" button opens a dialog box (Figure 22) which allows copying the current value to reference value. In the dialog, it is also possible to enable optical input power minor alarm limits and set them according to the current value with user specified margin, default  $\pm 2.0$  dBm.

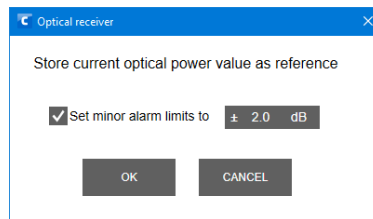

Figure 22. Forward path optical power reference dialog

### OLC offset

OLC offset can be used to increase/decrease internal RF levels after OLC operation to achieve very high/low output levels. See “Features / Forward path slope control” chapter for details.

### Output

The power consumption of the output hybrids can be minimised by enabling power save.

### OMI based alignment settings

When forward path OMI based alignment is started, it uses these values for forward path alignment. The “Transmitter OMI” is the OMI of the optical transmitter whose signal is received by this AC8710. “Output target” is the desired output 1 level.

**Pilots**

The "Pilots" button opens a dialog box (Figure 23) for configuring the pilots.

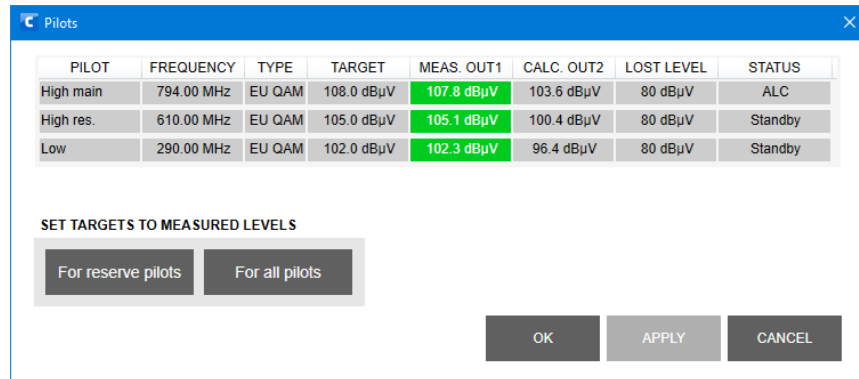

Figure 23. The Forward path pilots dialog

The pilot table consist of the following columns:

- **Pilot:** High main and reserve pilots are used by ALC and pilot based automatic alignment. Low pilot is used by pilot based automatic alignment only.
- **Frequency:** Pilot signal frequency, adjustable in 0.25 MHz steps. If 0 MHz is entered as pilot frequency, the pilot is disabled and thus not used in adjustment and no alarms of missing pilot are generated.
- **Type:** Detector type. The measurement detector can be individually selected for each pilot to be either peak detect "Analog" or averaging "EU QAM" (previously "Digital"), "US QAM" or "OFDM".
- **Target:** Pilot signal target level for ALC and automatic alignment.
- **Meas. out1:** Measured pilot signal level at output 1. The background colour is grey when pilot is disabled, red when its level is below lost level, green when its level is within ±1 dB from the target level, otherwise yellow.
- **Calc. out2:** Calculated level of pilot signal at output 2. The calculation is based on measured level at output 1 and gain and slope settings. The value is only informative with no accuracy specification.
- **Lost level:** Limit below which the pilot is considered as lost.
- **Status:** Pilot status and usage. "Disabled": pilot disabled. "Lost": Pilot level below lost level. "ALC": Pilot OK and used for gain adjustment. "Standby": Pilot OK but not used for adjustment.

The pilot signal frequency, type, target level and lost level can be edited by double-clicking a row in pilot table.

The "Set targets to measured levels" buttons can be used to set either reserve pilot or all pilot target levels according to measured levels. This can be used e.g. after manual adjustment of output levels, before activating ALC.

## Return path viewer page

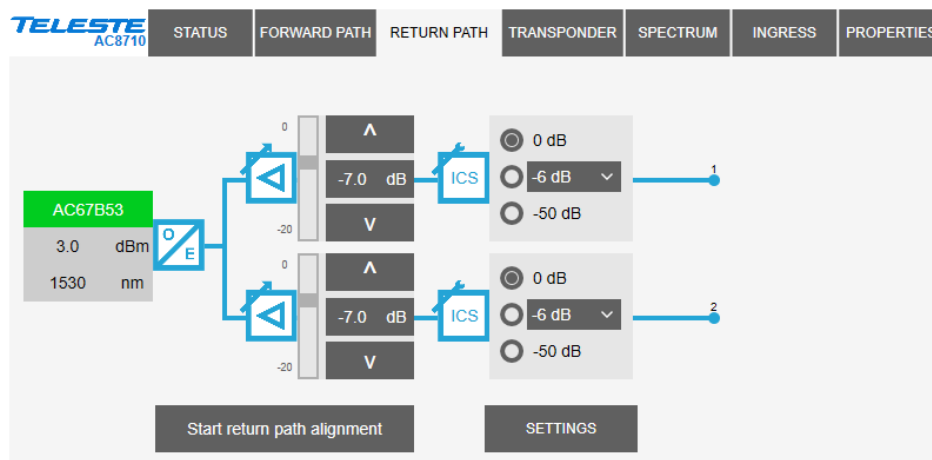

Figure 24. The Return path page

The “Return path” page displays all return path settings.

### Optical transmitter module

The type of transmitter module, nominal optical output power, and wavelength are displayed on the left next to the "O/E" symbols. The background colour of the transmitter type changes according to laser bias current alarms.

### Gain control

The return path gain field and up and down buttons can be used to adjust the return path signal levels in 0.5 dB steps. The slider indicates the relative position of the control to its limits.

### Ingress switches

The radio buttons are used to control the ingress switches. The “-50 dB” selection cuts off the incoming return path RF signal and thus also disconnects all transponders behind this node, but the AC8710 itself can still measure return path ingress and communicate with its modem.

The ingress switch attenuation value can be adjusted between 3...10 dB. This can be used to fine-tune the automatic ingress attenuation feature.

The ingress switches are read-only if automatic ingress blocking is enabled.

### Start return path alignment

Clicking the “Start return path alignment” button will start return path OMI based alignment. The adjustment parameters have to be set correctly via the "Settings" dialog before the adjustment is started. A dialog box is opened which displays the status of the alignment.

## Settings

The "Settings" button opens a dialog box (Figure 25) for configuring return path settings.

Figure 25. The Return path settings dialog

## Transmitter

The optical transmitter pilot signal frequency can be set to 5.5 MHz, 6.5 MHz, or disabled. Note that this feature is independent of the transponder module's pilot generator.

The transmitter module bandwidth is set automatically according to highest-frequency installed diplex filters.

## Automatic ingress blocking

The ingress measurement status is displayed on the top of the frame:

- **Ingress OK:** Ingress measurement results are within limits.
- **Ingress alarm:** Ingress measurements are above major alarm limits.
- **Ingress warning:** Ingress measurements are above minor alarm limits, but "Ingress alarm" is not active.
- **Ingress analyser off:** Ingress analyser is disabled by the user.
- **No transponder:** No transponder module installed.
- **Tuner module error:** Error in transponder tuner module.

When automatic ingress blocking (AIB) is enabled, ingress switches are controlled automatically based on ingress measurement results and activation and deactivation delays. AIB has 4 operation modes:

- **Disabled:** No automatic operation.
- **Alarm: Att:** "Ingress alarm" active for "Activation delay" time → attenuate. "Ingress alarm" off for "Deactivation delay" time → 0 dB.
- **Alarm: -50 dB:** "Ingress alarm" active for "Activation delay" time → -50 dB. "Ingress alarm" off for "Deactivation delay" time → 0 dB.
- **Warning: Att, Alarm: -50 dB:** "Ingress warning" active for "Activation delay" time → attenuate. "Ingress alarm" active for "Activation delay" time → -50 dB. Both off for "Deactivation delay" time → 0 dB.

The activation and deactivation delays can be used to fine-tune AIB. They should usually be selected so that delays are smaller deeper in the network.

**OMI based alignment**

When forward path OMI based alignment is started, it uses these values for return path alignment. RF input levels can be entered separately for each input, or use same value by entering just the input 1 value and checking "Use for all".

**Transponder pilot generator**

The pilot generator settings are available when AC6992 transponder is installed and the pilot generator feature is enabled with correct Product Key. Note that this feature is independent of the optical transmitter module's internal pilot generator.

The "Enable pilot generator" checkbox is the master switch for return path pilot generator. When the pilot generator is enabled, the transponder outputs one of the pilot signals for a user defined "Pilot duration", then switches to the next pilot signal and then repeats again. The "RF modem Tx freq" field shows the modem transmit frequency as a reminder.

Pilot frequency, level and enabling can be controlled for all four pilots separately. Equivalent input level for return path RF input 1 is shown next to each pilot. It takes into account return path losses, gain setting and ingress switch setting. When ingress switch is set to "-50 dB" the equivalent input level is shown as "N/A".

## Transponder viewer page (CATVisor)

This page is visible with AC6992 transponder in CATVisor mode.

The screenshot shows the 'Transponder' page in the TELESTE AC8710 interface. At the top, there are navigation tabs: STATUS, FORWARD PATH, RETURN PATH, TRANSPONDER (selected), SPECTRUM, INGRESS, and PROPERTIES. Below the tabs, a green bar indicates 'Connected (1.1)'. The page is divided into several sections:

- RECEIVER:**
  - FREQUENCY: 87.2 MHz
  - LEVEL: 90 dBµV (highlighted in green)
  - SCAN START: 80.0 MHz
  - SCAN STOP: 155.0 MHz
  - SCAN STEP: 0.1 MHz
- TRANSMITTER:**
  - FREQUENCY: 13.0 MHz
  - LEVEL: 104 dBµV (highlighted in green)
  - MIN LEVEL: 104 dBµV
  - MAX LEVEL: 104 dBµV
- TX LEVEL AT RETURN PATH INPUT:**
  - INPUT 1: 67 dBµV
  - INPUT 2: 67 dBµV
- COMMUNICATION SETTINGS:**
  - IP ADDRESS: 10.9.16.167
  - NET MASK: 255.255.255.255
  - MAC ADDRESS: 009050AC6992
- DEVICE GROUP:** A grid of 8 checkboxes, all of which are checked.
- PACKET STATISTICS:**
  - RECEIVED: 506
  - SENT: 500
  - BAD: 0
  - A 'RESET' button is present.
- COMMUNICATION PROTOCOL:** Radio buttons for 'CATVisor' (selected) and 'HMS'.

Figure 26. The Transponder (CATVisor) page

The “Transponder” page displays all the data and settings of the transponder’s RF modem and remote communication. See the “Features/Remote communication” chapter for details.

Changing any of the fields except transmitter min and max level on the "Transponder" page will reset RF modem communication.

### Connection status

The communication status of the transponder is shown at the top of the page with

- **Scanning:** Searching for the HEC carrier.
- **Data carrier found:** Waiting for communication parameters.
- **Registering:** Registration in progress.
- **Connected:** Registration complete, communication OK.

The number in parenthesis is a more detailed status indicator for diagnostics purposes, ranging from 0 to 11.

### Receiver

The “Frequency” data field shows the used receiver frequency.

The “Level” data field shows the measured signal level with a background colour indicating alarm status.

The “Scan start” and “Scan stop” fields determine the frequency band that the unit scans through when searching for the HEC carrier. Scanning can be disabled by setting the start and stop frequencies to the same value. Scanning speed can be improved by limiting the scanning range. The maximum range depends on the installed transponder type. The scan will start from the last known HEC carrier frequency.

The "Scan step" field sets the frequency increments of the scanning process, default and minimum value is 0.1 MHz.

### **Transmitter**

The "Frequency" data field shows the used transmitter frequency commanded by the HEC. The "Level" data field shows the transmitter signal level with background colour indicating alarm status.

The allowed range for transmit signal level can be set in the "Min level" and "Max level" fields. The maximum range depends on installed transponder type. If the HEC commands transponder to use transmit level outside this range, nearest allowed value is used and "Modem transmit level saturated" alarm is activated.

### **Tx level at return path input**

These fields show the calculated equivalent input level for the transponder transmit level. This is the signal level that needs to be injected to return path input to appear at return path output at same level than transponder signal. It takes into account return path losses, gain and ingress switch settings.

### **Communication settings**

The "IP address" field is used to define the IP address of the unit. The address has to be unique and match the HEC's IP subnet settings to ensure proper operation and IP level communication with the HEC.

If the IP address is set incorrectly, e.g. 0.0.0.0, the transponder can still communicate with the HEC on MAC level, but IP traffic (e.g. CATVisor messages) is not possible. It is possible to set the IP remotely via the HEC.

The "Net mask" field defines the corresponding IP subnet. It is only needed for broadcast software updates and has to be set according to the HFC subnet of the HEC; otherwise it can be left as 255.255.255.255.

The "MAC address" is the unit's unique, read-only hardware address that is also printed on the transponder front panel sticker.

### **Device group**

Manageable devices in the same HFC network can be divided into different device groups. The "Device group" check boxes can be used to group transponders under multiple HECs. For more information, see HEC manual.

### **Packet statistics**

The "Received" field displays the total number of IP packets addressed to and received by this unit.

The "Sent" field displays the total number of IP packets sent by this unit.

The "Bad" field displays the number of all bad packets received and is a good indicator of the forward path condition.

Packet counters wrap around at 65535, so absolute values are not meaningful.

The "Reset" button will reset all packet counters to zero.

---

**Communication protocol**

It is possible to change between CATVisor and HMS on the fly. Careful planning is needed in e.g. HEC / HMTS setup for successful change, especially over remote connection. Changing the setting and clicking "Apply" will open a dialog for entering parameters specific for the selected protocol. After accepting the values the unit will reset and start communication using the new protocol.

## Transponder viewer page (HMS)

This page is visible with AC6992 transponder in HMS mode.

Figure 27. The Transponder (HMS) page.

The "Connection status", "Receiver", "Transmitter", "Packet statistics", "Tx level at return path input" and "Communication protocol" frames are the same as in the CATVisor version of this page and are described in the preceding chapter.

HMS standard does not support automatic transmit level alignment and therefore the transmit level is manually adjusted in the HMS version. See "Features"/"Remote communication" chapter for details.

### IP address

This is the transponder's IP address. In HMS this field is just a storage place. Depending on the used addressing method, the HMTS may or may not use this value. It may also change this value using MAC layer commands.

### MAC

**Unicast MAC:** The transponder's globally unique MAC layer address.

**CHNLDESC timeout:** HMTS broadcasts periodically the CHNLDESC packet that informs the transponders about data channel frequencies. This timeout defines how long the transponder waits for an eventual CHNLDESC packet, to define whether the carrier is an HMS channel. After the transponder is registered, it uses a timeout twice as long as the set value, to avoid the transponder from leaving the channel in case the reception of one CHNLDESC is unsuccessful.

**Poll timeout:** If the transponder receives no packets to its own MAC address, it will wait up to this timeout, before declaring itself as 'forgotten' by the HMTS. After this timeout expires, the transponder will start reregistration.

**"Period", "Ack timeout", "Retries", "Kmin", "Kmax":** These values are used by the backoff calculation algorithm, in case a collision happens in the return path transmission (two or more transponders transmitting simultaneously). These values are for experts only and should be changed only in special cases.

**SNMP communities**

SNMPv1 community strings. The transponder will only accept SNMP GET/GET NEXT commands containing the Read or Write community string and SET commands containing the Write community string. Traps are sent containing the Trap community string. Communities can be adjusted **only locally**.

**SNMP traps**

**Enabled:** Enables/disables the sending of HMS SNMP traps.

**Delay:** The time to wait before sending an HMS alarm trap, once an alarm is detected. This parameter can be used to control trap storms in amplifier cascades. By setting a longer delay deeper in the cascade, traps can be set to arrive on due order.

**Interval:** The minimum time between successive traps. This parameter applies only if several alarms are detected simultaneously.

**Lifetime:** The time the transponder keeps an HMS alarm trap in the transmit queue, if it cannot be sent for some reason (controlled by HMTS).

All trap parameters are adjustable also remotely via TELESTE-COMMON-MIB. Teleste MIBs are available at Teleste extranet (MyTeleste).

## Transponder viewer page (DOCSIS)

This page is visible with AC6981 and AC6983 transponders.

operational (12)			
<b>RECEIVER</b>		<b>DOCSIS MODULE</b>	
FREQUENCY	706.00 MHz	CURRENT TIME	6.11.2015 14:48
LEVEL	98 dBμV	PUBLIC IP ADDRESS	10.9.19.179
MODULATION	QAM256	MAC ADDRESS	009050D22AAC
S/N RATIO	38 dB	HARDWARE VERSION	1A
<b>TRANSMITTER</b>		SERIAL NUMBER	253147012396
FREQUENCY	25.0 MHz	SOFTWARE VERSION	2.20.3.14 R3p30
LEVEL	100 dBμV	<b>RESET DOCSIS</b>	
CHANNEL ID	1		
BANDWIDTH	3.2 MHz		
<b>TX LEVEL AT RETURN PATH INPUT</b>		<b>PACKET STATISTICS</b>	
INPUT 1	63 dBμV	RECEIVED	45495
INPUT 2	63 dBμV	BAD	0
		SENT	45519
		<b>RESET</b>	

Figure 28. The Transponder (DOCSIS) page

The “Transponder” page displays read-only status information on DOCSIS communication. See the “Features/Remote communication” chapter for details.

### Connection status

The communication status of the transponder is shown at top of the page. The number in parenthesis is a more detailed status indicator for diagnostics purposes, ranging from 1 to 13.

### Receiver

The used forward path frequency, receive level at transponder input and modulation are shown in respective fields. "S/N ratio" is the measured signal to noise ratio at DOCSIS receiver.

### Transmitter

The return path frequency, transmit level at transponder output, channel ID and bandwidth are shown in respective fields.

### Tx level at return path input

This is the signal level that needs to be injected to return path input to appear at return path output at same level than transponder signal. The calculation takes into account return path losses, gain and ingress switch settings.

### DOCSIS module

The current time and public IP address obtained from CMTS are shown in respective fields together with DOCSIS module hardware version, serial number, and software version. DOCSIS module software can be updated only remotely via CMTS using DHCP/TFTP. The MAC address is the unit’s unique, read-only hardware address that is also printed on the transponder front panel sticker.

The "Reset DOCSIS" button forces the module to re-establish the communication link.

**Spectrum viewer page**

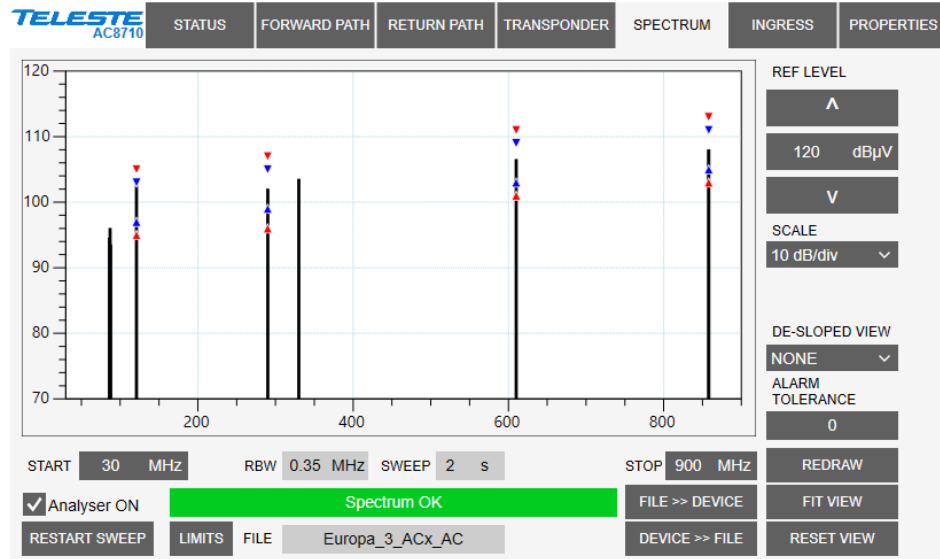

Figure 29. The Spectrum page

When the spectrum analyser feature is enabled with correct Product Key, the "Spectrum" viewer page presents forward path level measurements in a graphical "spectrum analyser" display. Up to 100 measurement frequencies with individual detector type and alarm limits can be specified with a simple text file. The measurement results can be saved back to a text file.

**Display settings**

When the viewer page is opened, the measurement results are retrieved from the device and displayed. The display can be zoomed or re-centred by entering new values into start and stop frequency, reference level and scale dialogs and clicking "Redraw" button. The "Fit view" button scales the display so that all measurement frequencies are visible; "Reset view" button restores full-scale display.

The RBW (resolution bandwidth) is fixed by transponder hardware and depends on the installed transponder type, see transponder spec sheet.

The "Sweep" field displays the last elapsed time it took to scan through the complete set of measurement frequencies.

The "De-sloped view" field can be used to simulate a view of a flat frequency response by reducing the level at the high end of the node's response. The signal level at 1218 MHz is displayed with the attenuation specified in "De-sloped view", the signal level at 85 MHz is not affected at all and attenuation of the frequencies between these two are calculated using a standard coaxial cable model. The "De-sloped view" function acts only as a visual aid for making adjustments and does not affect device operation in any way.

If the graphical display is clicked the frequency, measured level, detector mode, and possible alarm limit values of the clicked measurement are displayed next to the clicked point.

## Limits

The alarm limits for each measurement frequency are shown in the graph with blue triangles for minor limits and red triangles for major limits. If a measurement is over major limit it will be drawn in red; in blue if it is over minor limit; otherwise in black.

The "Tolerance" field specifies how many measurements are allowed to be outside limits before the "Spectrum warning" or "Spectrum alarm" alarm is activated. The default value 0 will generate the alarm even if only one value is outside limits. "Tolerance" allows fine-tuning the limit testing so that e.g. it doesn't react to one missing channel. The alarm is set or cleared at the end of each measurement cycle.

There is a fixed 1 dB hysteresis to prevent alarm toggling: once activated, the alarm only goes off when the measurement result is within (limit – 1 dB).

The "Limits" button opens a dialog box (Figure 30) which allows setting the alarm limits according to measured values, with user-specified offsets separately for minor and major alarm limits. The limit values are written also to the sweep file, and not to device at all if "Save limits only to file" is checked.

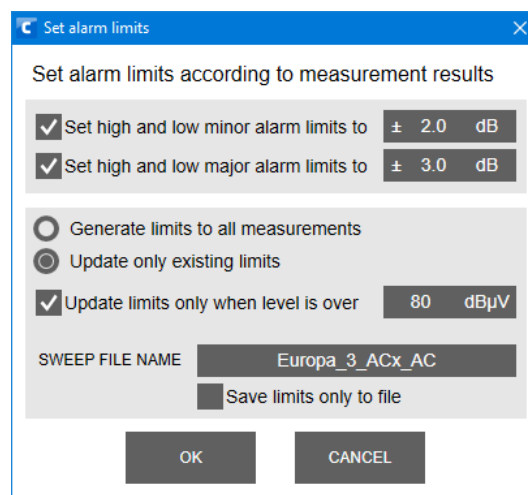

Figure 30. The Set alarm limits dialog

## Analyser settings

The "Analyser on" is the master switch for spectrum analyser feature.

The data field next to "Analyser ON" check box displays the spectrum status: Spectrum OK / Spectrum warning / Spectrum alarm / Spectrum analyser off.

The "Restart sweep" button clears the measurement results table and restarts the sweep. The "Current sweep file" field displays the first 15 characters of the filename of the last sweep file downloaded to the device.

The "File >> Device" and "Device >> File" buttons open a file dialog for transferring a sweep/result file to/from the device.

## Sweep and result file formats

The sweep file is a simple text file that can be edited with any text editor and most spreadsheet applications. Each line in the sweep file defines one

measurement frequency, preferably in ascending order. Each line has 2-6 fields separated with tab characters and dot (.) as the decimal separator:

- 1) The measurement frequency in multiples of 0.25 MHz.
- 2) The detector type:
  - **A**: analog peak detection
  - **D**: digital averaging detection (EU QAM)
  - **U**: digital averaging detection (US QAM)
  - **O**: digital averaging detection (OFDM)
- 3) Optional low major alarm limit in multiples of 0.5 dB $\mu$ V.
- 4) Optional low minor high limit in multiples of 0.5 dB $\mu$ V.
- 5) Optional high minor alarm limit in multiples of 0.5 dB $\mu$ V.
- 6) Optional high major alarm limit in multiples of 0.5 dB $\mu$ V.

Comments can be inserted at the end of the line, preceded with a tab character, or on a separate row that starts with a non-numeric character. Comments are for information only and will not be downloaded into the device and so they are lost if result table is uploaded back from device.

An example of a valid sweep file:

```
113      D      96.0  98.0   103.5  105.5  All four limits
121.00 D      101                                     Low major alarm
126.25 A                                     No limits
133.25 A                                     95          High minor alarm
```

The result file format is identical to the sweep file format, except that it has a header row and an additional last column that contains the measurement results.

## Ingress viewer page

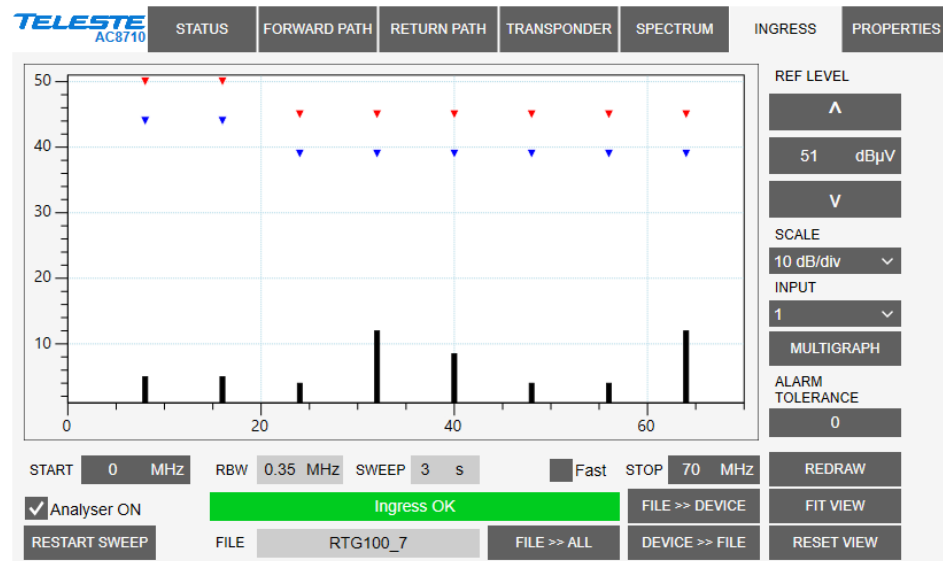

Figure 31. The Ingress page

When the ingress analyser feature is enabled with correct Product Key, the "Ingress" viewer page presents return path level measurements in a graphical "spectrum analyser" display. Up to 30 measurement frequencies with individual detector type selection and alarm limits can be specified with a simple text file. The measurement results can be saved back to a text file.

### Display settings

When the viewer page is opened, the measurement results are retrieved from the device and displayed. If the graph is clicked the frequency, level, detector type and alarm limits of the measurement are displayed next to the clicked point. The display can be zoomed or re-centred by entering new values into start and stop frequency, reference level and scale fields and clicking "Redraw" button. The "Fit view" button scales the display so that all measurement frequencies are visible; "Reset view" button restores full-scale display.

The "Input" radio button selects the displayed return path input. The ingress measurement file, tolerance and all display settings are individual for each channel, but the ingress analyser main switch is common for both inputs.

The RBW (resolution bandwidth) is fixed by transponder hardware and depends on the installed transponder type, see transponder spec sheet. Due to the roll off of the RBW filter, a signal-free area is needed if noise levels are measured.

The "Sweep" field displays the last elapsed time it took to scan through the complete set of measurement frequencies.

The "Fast" checkbox forces the viewer to update the ingress measurement results faster, but does not affect the actual measurement speed.

The "Multigraph" button displays all return path inputs simultaneously.

## Limits

The alarm limits for each measurement frequency are shown in the graphical display with red triangles for alarm limit and blue triangles for warning limit. If a measurement is over alarm limit it will be drawn in red; in blue if it is over warning limit but not over alarm limit; otherwise in black.

The "Tolerance" field specifies how many measurements are allowed to be over limits before the "Ingress warning" or "Ingress alarm" alarm is generated. The default value 0 will generate alarm even if only one value is outside limits. The alarms are set or cleared at the end of each measurement cycle.

There is a fixed 1 dB hysteresis to prevent alarm toggling: once activated, the alarm only goes off when the measurement result is within (limit – 1 dB).

## Analyser settings

The "Analyser on" is the master switch for ingress analyser feature.

The data field next to "Analyser ON" check box displays the ingress status: Ingress OK / Ingress alarm / Ingress warning / Ingress analyser off.

The "Restart sweep" button clears the measurement results table and restarts the sweep. The "File" field displays the first 15 characters of the filename of the last sweep file downloaded to the device for selected input.

The "File >> Device" and "Device >> File" buttons open a file dialog for transferring a sweep/result file to/from the device. The "File >> All" button transfers the same sweep file to all return path in-puts.

## Sweep and result file formats

The sweep file is a simple text file that can be edited with any text editor and most spreadsheet applications. Each line in the sweep file defines one measurement frequency, preferably in ascending order. Each line has 2-4 fields separated with tab characters and dot (.) as the decimal separator:

- 1) The measurement frequency in multiples of 0.25 MHz.
- 2) The detector mode as "A"/"Analog" for peak detection or "D"/"Digital" for averaging measurement.
- 3) Optional warning limit in multiples of 0.5 dB $\mu$ V.
- 4) Optional alarm limit is in multiples of 0.5 dB $\mu$ V.

Comments can be inserted at the end of the line, preceded with a tab character, or on a separate row which starts with a non-numeric character. Comments are for information only and will not be downloaded into the device and so they are lost if result table is uploaded back from device.

An example of a valid sweep file:

```
Measures return path lowest frequencies
5.00    D      35.0    40.0    Comment
7.50    D      35.0    40.0    Another comment
10.00   D      35.0    40.0
12.50   D      35.0    40.0
```

The result file format is identical to the sweep file format, but it has a header row and an additional column which contains the measurement results.

**Properties viewer page**

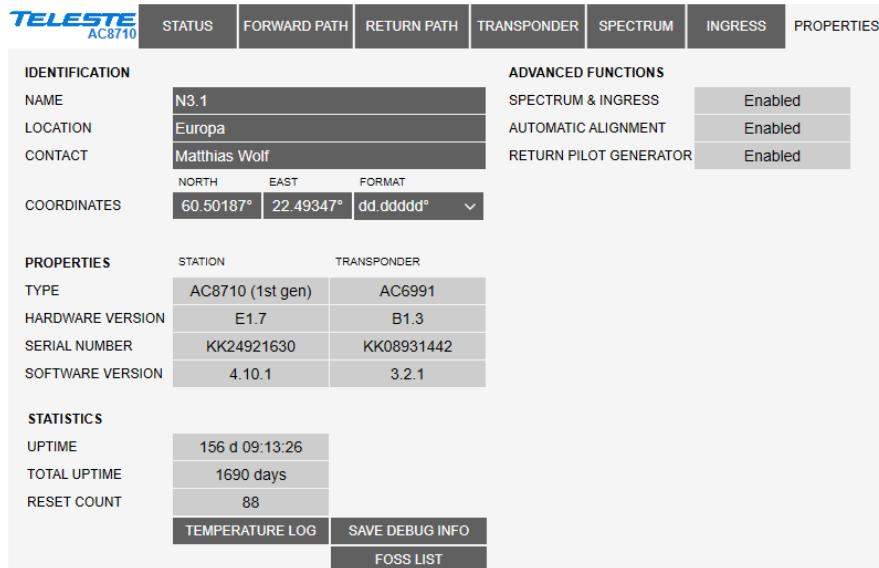

Figure 32. The Properties page

The “Properties” page displays unit identification and statistics data.

**Identification**

A descriptive alias name for the station can be entered into the “Name” field, site location into “Location” field and contact information into “Contact” field. All these fields can contain up to 63 characters.

The geographical coordinates can be entered into respective latitude and longitude fields. The preferred format can be selected from the drop-down field. When entering coordinates, special characters (°/'/'") can be simply omitted.

**Properties**

The type, hardware version, serial number, and software version are shown for both station and transponder.

**Advanced functions**

The statuses of advanced functions associated with Product Key are shown. These fields only indicate that the function is possible in the software, but does not display whether correct transponder module is installed for that function.

**Statistics**

The “Uptime” field shows the time since the last reset or power up. The format is days, hours, minutes and seconds, with ±5 s/day accuracy.

The "Total uptime" field shows the total number of full operating days.

The "Reset count" field shows the total number of resets.

The “Temperature log” button opens a histogram chart of the unit internal temperature history. The histogram shows the total number of operating hours of the unit in 10 °C steps between 0 (i.e. < 5) and 90 (i.e. > 85) °C.

The "Save debug info" button reads the unit's non-volatile memory contents and opens a dialog for saving it into "devicetype-serial-date.fun" and ".sad" files which can then be sent to Teleste support to help troubleshooting problems.

---

## Legal declarations

Copyright © 2017-2021 Teleste Corporation. All rights reserved.

TELESTE is a registered trademark of Teleste Corporation. Other product and service marks are property of their respective owners.

This document is protected by copyright laws. Unauthorized distribution or reproduction of this document is strictly prohibited.

Teleste reserves the right to make changes to any of the products described in this document without notice and all specifications are subject to change without notice. Current product specifications are stated in the latest versions of detailed product specifications.

To the maximum extent permitted by applicable law, under no circumstances shall Teleste be responsible for any loss of data or income or any special, incidental, consequential or indirect damages howsoever caused.

The contents of this document are provided "as is". Except as required by applicable law, no warranties of any kind, either express or implied, including, but not limited to, the implied warranties of merchantability and fitness for a particular purpose, are made in relation to the accuracy, reliability or contents of this document.

Teleste reserves the right to revise this document or withdraw it at any time without notice.



Teleste Corporation  
P.O. Box 323  
FI-20101 Turku  
Street address: Telestenkatu 1, 20660 Littoinen  
FINLAND

[www.teleste.com](http://www.teleste.com)







***TELESTE***