

Luminato Series

LUMINATO X32

VERSATILE MINI EDGE QAM FOR COST-EFFECTIVE TV DELIVERY

The Teleste Luminato X32 efficiently converts SPTS/MPTS IP streams into high-quality QAM signals at points where fiber meets coax, making it ideal for HFC segments, MDUs, and hospitality installations. It seamlessly replaces legacy RF overlay solutions and complements PON architectures, enabling QAM delivery without IP set-top boxes.

As part of Teleste's widely recognized Luminato product family, the Luminato X32 combines field-proven headend reliability with unique edge capabilities tailored to demanding network-edge deployments. Building upon the extensive global footprint of Luminato technology, the X32 provides operators with unmatched confidence in broadcast signal quality, operational simplicity, and service uptime—essential for delivering consistently superior user experiences.

TELESTE

LUMINATO X32 MINI EDGE QAM PART OF THE PROVEN TELESTE LUMINATO VIDEO HEADEND FAMILY

The Luminato X32 extends Teleste's globally trusted Luminato headend platform into compact edge deployments, combining proven reliability with advanced operational capabilities. It provides a cost-effective solution for deployments where the subscriber count per device is smaller, or for operators planning to adopt Remote PHY devices (RPDs) for broadcast delivery but who require robust video monitoring capabilities not available in standard Distributed Access architectures. The X32's innovative design allows operators to efficiently deliver high-quality broadcast TV services while benefiting from reduced operational costs and simplified maintenance.

High-quality Broadcast TV Services for Versatile Deployments

- Traditional Edge QAM functionality, providing reliable broadcast TV delivery in cable networks.
- Eliminates hard-to-maintain EDFA cascades, simplifying broadcast TV distribution by replacing legacy RF-overlay architectures.
- Easy integration with PON, allowing delivery of broadcast TV services without requiring IP-based set-top boxes.
- Cost-effective solution for smaller-scale deployments, efficiently delivering linear TV in locations such as hospitality environments, campus areas, and multi-dwelling units.

Key Features

- **32 Independent QAM Channels** – Compact, high-density QAM modulation.
- **High-Throughput 10G IP Input** – Efficient handling of SPTS/MPTS IP streams via SFP+ optical/electrical interface.
- **Centralized Remote Management** – Easy unit configuration and monitoring with CLI, SNMP, WebUI, and REST API.
- **Silent and Reliable Operation** – Passive cooling eliminates noise and reduces maintenance.
- **All-Inclusive Functionality** – Standard configuration includes all essential features, ensuring straightforward procurement, simplified logistics, and exceptionally easy operation.

Flexible Installation – Rack or Wall Mountable

The Luminato X32 is designed for versatile installation, allowing operators to choose between secure wall-mounting with minimal space requirements or integration into a standard 19-inch rack using the optional assembly plate. Its sophisticated passive cooling design ensures consistently high performance, silent operation, and enhanced reliability, making it suitable for a wide variety of deployment environments.



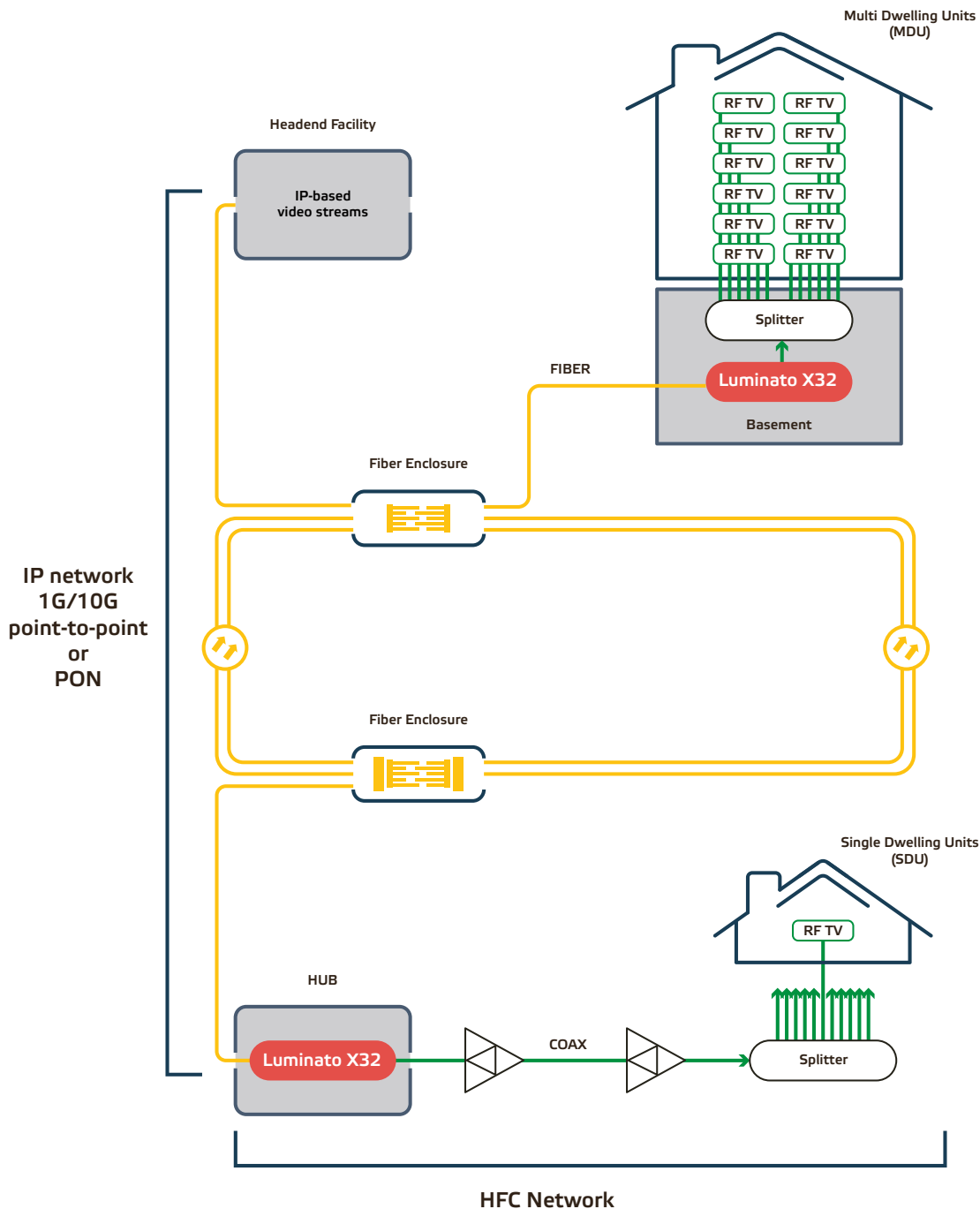

Seamless TV Delivery Across Diverse Networks

The Luminato X32 extends the renowned reliability and proven performance of Teleste’s globally deployed Luminato headend family into compact, network-edge scenarios. Operators worldwide trust Luminato technology for delivering high-quality broadcast services, and the X32 builds directly on this heritage. Sharing a common heritage of reliability and proven technology, the Luminato 4X4 and X32 independently deliver exceptional performance. An option to deploy both devices within the same network enables operators to achieve consistent, carrier-class broadcast quality throughout the entire infrastructure.

Enhanced Flexibility & Simplified Management

Designed to maximize operational flexibility, the Luminato X32 supports centralized management through Teleste’s Argus Luminato Manager, along with versatile device configuration via CLI, WebUI, and an open REST API. SNMP monitoring and traps further streamline daily operations by enabling convenient real-time device monitoring. Operators can easily manage individual units or larger deployments remotely, simplifying tasks, enhancing responsiveness, and ensuring consistently high service quality.

LUMINATO SERIES

IP INPUT		REMOTE MANAGEMENT & MONITORING	
Port	Slot for Ethernet/IP SFP/SFP+ 1G and 10G (Optional SFP/SFP+ modules not included)	Port	SFP/SFP+ 1G and 10G, Ethernet 100M RJ45 and USB-C for local management (Optional SFP/SFP+ modules not included)
Number of Inputs	1000 IP multicast inputs	Centralized Mgmt. System	Teleste Argus Luminato Manager
Input Streams	IP address / UDP port selector for input streams	CLI/WebUI	Accessing single units
Max Number of PIDs	4000	SNMP	Version 2, SNMP traps for monitoring
Payload VLAN	Tagged and untagged, user configurable	API	REST API
MPEG-2 TS over UDP/RTP	Free-to-air and pre-encrypted	Software Upgrades	HTTP or TFTP
Multicasting	IGMP v3	Monitoring	Input TS bitrate, Dejittering buffer overflow, Multiplex over-allocation warning, Current and peak bandwidth allocation of multiplex
ADVANCED STREAM PROCESSING		QAM RF OUTPUT	
Network de-jittering	Including PCR restamping, capable of inserting and removing null PIDS	Connector	F-connector, 75 ohm
Stream processing	Multiplexing and pass-through	Standard	ITU-T J.83 (Annex A, B), DOCSIS CM-SP-DRFI-I16-170111
EXTERNAL POWER SUPPLY		QAM Constellations	16, 32, 64, 128, 256
Power Unit	Class I	Symbol Rate	4...7.1 MBd
Input Voltage	90...264 VAC	Number of QAM Outputs	Up to 32 pcs, All channels can be independently placed (50...900 MHz)
AC inlet	IEC320-C14	Output Return Loss	>14 dB, on active channel >12 dB, out of act. ch (81...862 MHz) >10 dB, out of act. ch (862...1006 MHz)
Output Power/Voltage	60 W /18 VDC	Output Level	42 dmV (102 dBuV), 21...32 active chs 44 dmV (104 dBuV), 17...20 active chs 45 dmV (105 dBuV), 13...16 active chs 47 dmV (107 dBuV), 7... 12 active chs 50 dmV (110 dBuV), 1...6 active chs
Dimensions (H x W x D)	34 mm x 53 mm x 117 mm 1.4" x 2.1" x 4.6"	Output Level Adjustment	10 dB
Weight	0.3 kg, 0.66 lbs	Output Level Step Size	0.2 dB
Operating Temp. Range	0...+50 °C, 32...+122 °F	Output Center Frequency	50... 900 MHz and 100...1000 MHz
EMC Compatibility	EN 50083-2; EN61000; EN55032; Class B, FCC Part 15	Output Freq. Accuracy	± 30 kHz
GENERAL		Out of Band Noise	<-60 dBc, 1st adjacent channel <-64 dBc, 2nd adjacent channel <-70 dBc, 3rd adjacent channel <-70 dBc, other channels
Cooling	Passive	Phase Noise	-33 dBc, 1 kHz...10 kHz -51 dBc, 10 kHz...50 kHz
Dimensions (H x W x D)	65 mm x 160 mm x 305 mm 2,6" x 6,3" x 12"	Harmonics	<- 63 dBc
Weight	3 kg, 6.6 lbs	EqMER	>45 dB
Wall Mount Brackets	Integrated		
Cabinet Installation Frame	Optional, 19" 2U		
Enclosure Classification	IP20		
Power Consumption	35 W		
Operating Temp. Range	0...+50 °C, 32...+122 °F		
EMC Compatibility	EN 50083-2; FCC part 15		



TELESTE CORPORATION
www.teleste.com

P4P_X32_1125

Copyright © 2025 Teleste Corporation. All rights reserved. Teleste and the Teleste logo are registered trademarks of Teleste Corporation. Other product and service marks are property of their respective owners. Teleste reserves the right to make changes to any features and specifications of the products without prior notice. Although the information in this document has been reproduced in good faith, the contents of this document are provided "as is". Teleste makes no warranties of any kind in relation to the accuracy, reliability or contents of this document, except as required by applicable law.